



**INSTALLATION
AND
OPERATING
INSTRUCTIONS**

FRY HOLDING BIN
Model: **CFHS Series**



RETAIN THIS MANUAL FOR FUTURE REFERENCE

WARNING

Improper installation, operation, service, or maintenance can cause property damage and/or result in personal injury. Read this manual thoroughly before installing, operating, or servicing this equipment.

SAFETY PRECAUTIONS

APW Wyott's equipment is designed, built and sold for commercial use and should be operated by trained personnel only. Make sure all CAUTIONS, WARNINGS and operating instructions are clearly posted near each unit to insure proper operation and reduce the chance of personal injury and/or equipment damage.

Always disconnect power before cleaning or servicing the unit. Surfaces will remain hot after power has been removed, allow unit to cool before cleaning or servicing. Never clean the unit by immersing it in water. The unit is not protected against water jets; **DO NOT CLEAN UNIT WITH A WATER JET.** Always clean equipment properly before first use.



ANSI/NSF4

Phone: (214) 421-7366
Fax: (214) 565-0976
Toll Free: (800) 527-2100
Website: www.apwwyott.com
E-mail: info@apwwyott.com

P/N: 95000018 9/05

APW WYOTT
Foodservice Equipment Company
729 Third Avenue, Dallas, TX 75226

1. GENERAL INFORMATION

Check the rating label for your model designation and electrical rating. Rating Label is located on the rear base of the unit.

- **Overall dimensions:**

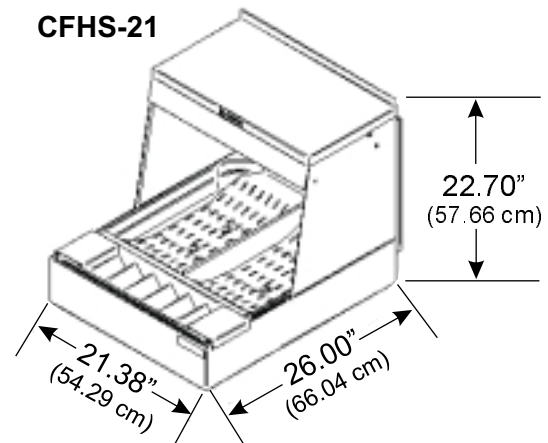
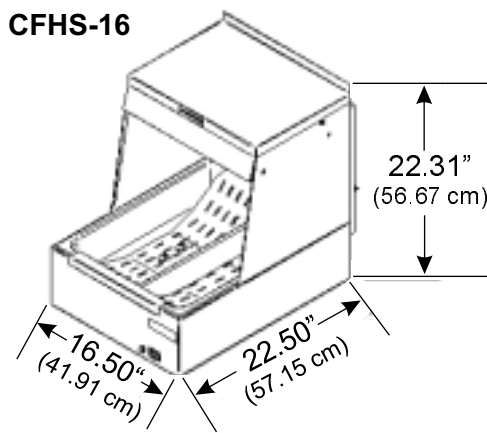

- **Electrical ratings:** CFHS-16 120VAC, 880W, 60Hz, 7.33A, NEMA 5-15 Plug
CFHS-21 120VAC, 1130W, 60Hz, 9.42A, NEMA 5-15 Plug
- **Power Cord:** 6 foot, 3 wire grounded cord. If the supply cord is damaged, the manufacturer or an authorized service agent or a similarly qualified person must replace it in order to avoid a hazard.
- **Shipping Weight:** CFHS-16 40.0 lbs. (18.14 kg)
CFHS-21 50.0 lbs. (22.68 kg.)

2. INSTALLATION

The Fry Holding Station is shipped with the ribbon (model CFHS-21 only), divider and trivet assembled. Care should be taken when removing unit from box, as ribbon, divider and trivet are free to move.

1. Remove unit from shipping container while in the upright position.
2. Remove all internal packaging.
3. Inspect bin area for damage. This includes ceramic elements and light bulbs in overhead assembly.
4. If unit needs to be wiped down please use damp cloth with warm water.
5. Unit should now have components in place as shown in Figure 1.
6. Place unit in operating location.

Note: Ambient Conditions

Make sure that the operating location is in an area where the ambient temperature is held constant (minimum 70°F). Please avoid areas such as near exhaust fans, hoods and air conditioning ducts.

Warning: Operating environment

Ensure that operation location is at a reasonable distance from combustible walls and materials otherwise combustion or discoloration could occur.

Caution: Operating environment

Place unit on a stable counter at a convenient height for use. The lid of the Fry Holding Station is not intended to be used as a shelf. Objects over 25lbs (11.33kg) should not be placed on top of unit.

7. Before plugging unit into wall, make sure that the switch is in the off or "0" position.
8. Plug unit into grounded electrical outlet with correct voltage, and plug configuration.



Figure 1.

3. OPERATION INSTRUCTIONS

1. The On/Off switch should be in the offline position "0".
2. Flip switch to online position "1".

Caution: *External Surface Temperatures*

The unit's external surface temperatures will be hot. Use caution when touching these areas to avoid injury.

Warning: *Severe Burns - Ceramic Elements*

Ceramic elements operate at high temperatures. **Do not touch elements after power is applied to the elements.** Incorporated into the front surface of the element is a **red color changing decal**. As the element reaches a certain temperature the decal will change from red to black. The decal will remain black until the element falls below the transition temperature where it will then return to its original red color. However, the element even if red will still be extremely hot. This color changing decal is used only for determining if element is operational.

4. CLEANING INSTRUCTIONS

Warning: *Unplug Power*

Before cleaning, ensure that the unit is unplugged and its components are cooled down. There should be no power going to the unit.

Warning: *Cleaning*

Never spray water on the unit or controls nor submerge unit in water. Damage to the unit as well as injury could occur. Injury and burns may occur if you do not follow this instruction sheet.

Cleaning should be done Daily.

1. Clean outside with warm soapy water and a soft cloth only. Mild degreaser can be used. Do not use abrasive cleaners, as they will scratch the finish, which could induce dirt accumulation.
2. **DO NOT USE ANY** solvents or acetone type cleaner. They will damage the sealant.
3. Once a week, clean the inside of the cabinet with warm soapy water and a soft cloth only. Mild degreaser can be used.

5. TROUBLESHOOTING

Always ask and check the following:

1. Is the unit connected to a live power source of the proper voltage?
2. Check the circuit breaker.
3. Is power switch "ON" and lights glowing?
4. Check the rating label. Is the unit connected to the correct power source?
5. If the above checks out, and you still have problems, call your local service agent.

6. REPLACEMENT PARTS

EXPLODED VIEW

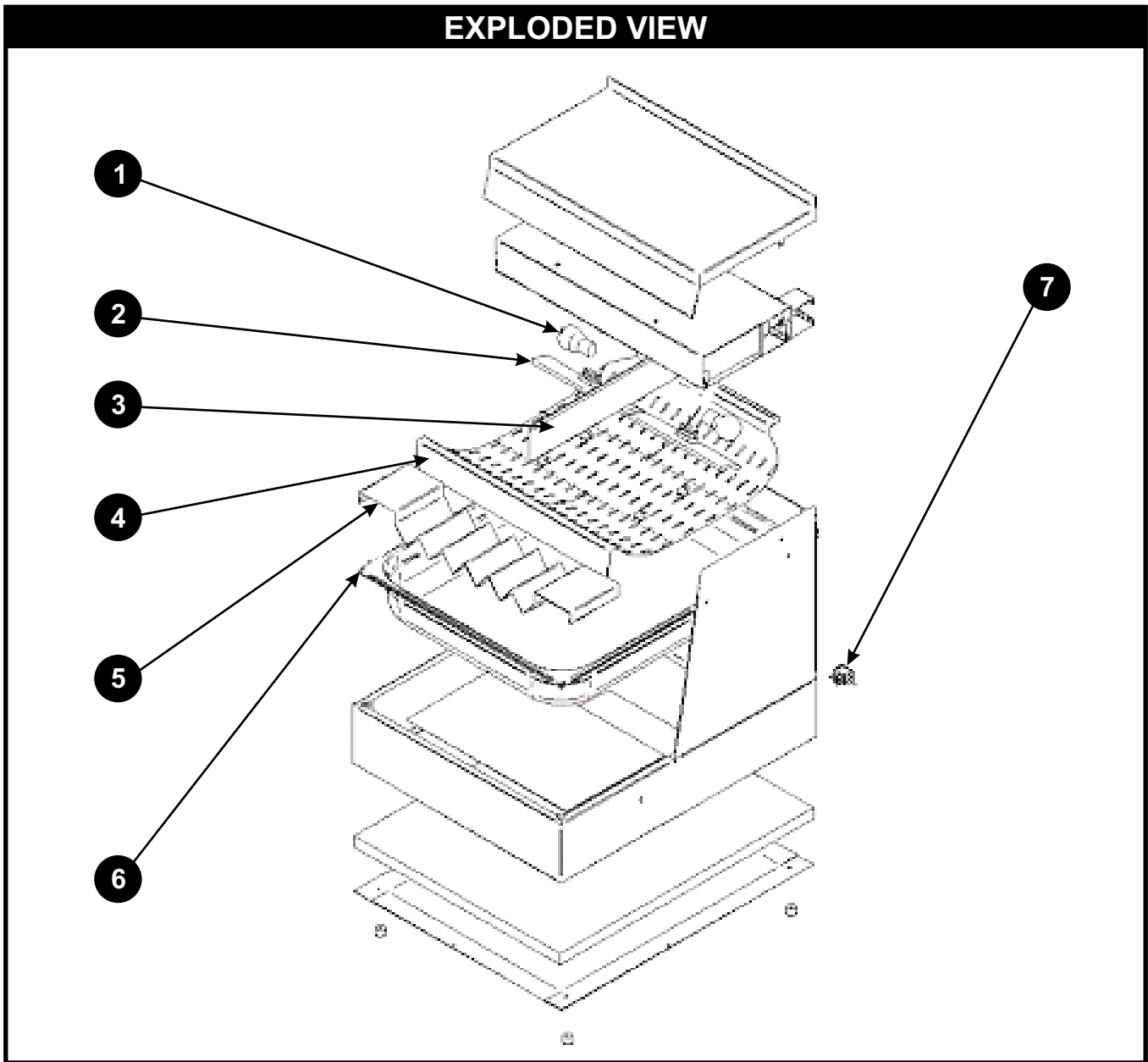

REPLACEMENT PARTS LIST

ITEM	PART NUMBER	DESCRIPTION	QUANTITY
1	75916	Lamp, 40w, Teflon Coated	2
2	9500026	Element, Ceramic, CFHS-21	2
	9510006	Element, Ceramic, CFHS-16	1
3	9500035	Divider, Trivet	1
4	9500005	Trivet, CFHS-21	1
	9510021	Trivet, CFHS-16	1
5	9500036	Ribbon, 6 Bag (CFHS-21 only)	1
6	9500046	Pan w/Bottom Heater, CFHS-21	1
	9510020	Pan w/Bottom Heater, CFHS-16	1
7	89488	Switch	1
8	9500041	Thermostat (Not Shown)	1

7. WIRING DIAGRAMS FOR CFHS SERIES

CFHS-21

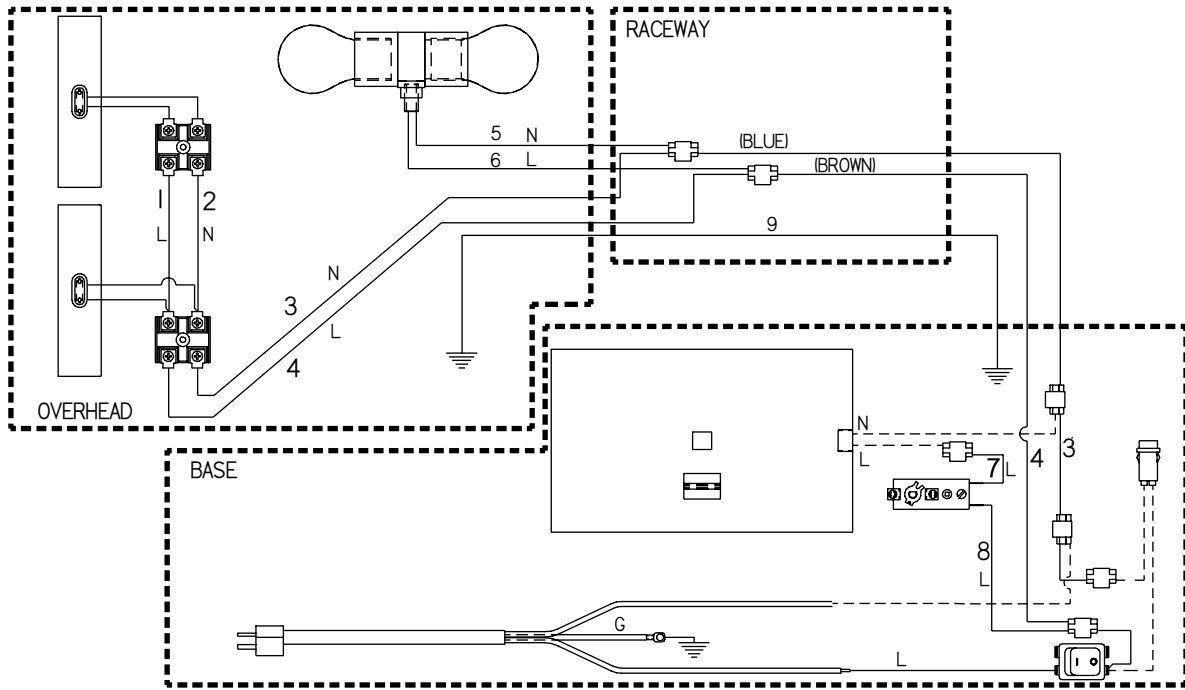

CFHS-16

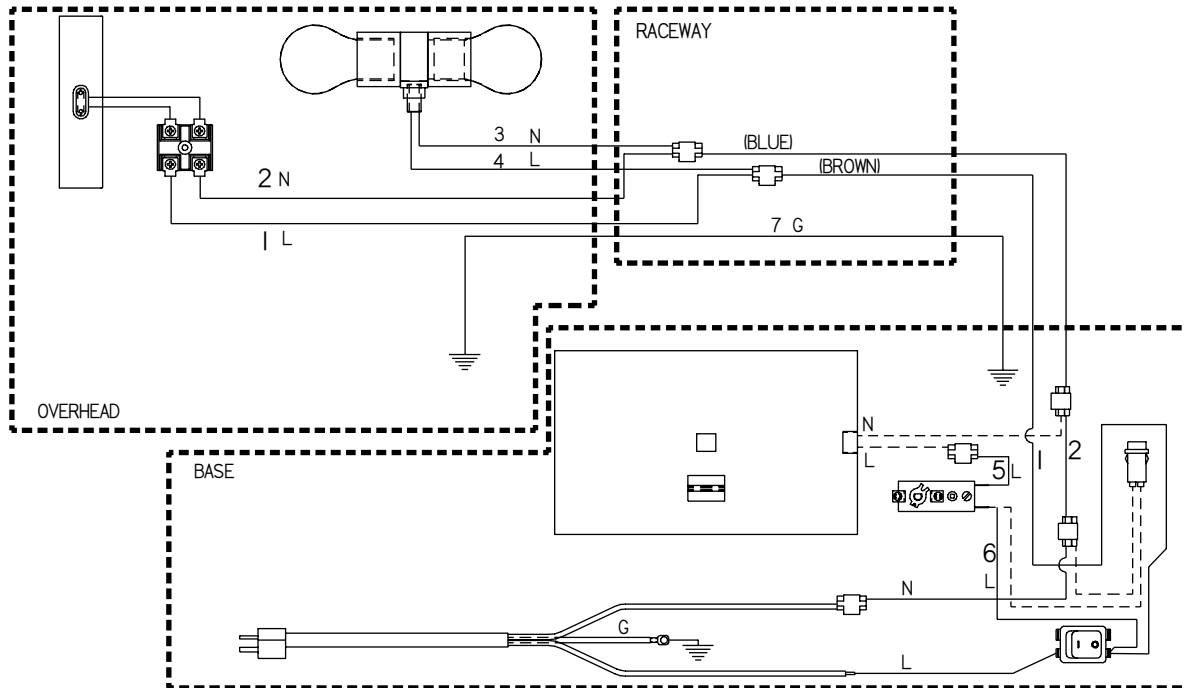

8. APW WYOTT EQUIPMENT LIMITED WARRANTY

APW Wyott Foodservice Equipment Company warrants its equipment against defects in materials and workmanship, subject to the following conditions:

This warranty applies to the original owner only and is not assignable.

Should any product fail to function in its intended manner under normal use within the limits defined in this warranty, at the option of APW Wyott such product will be repaired or replaced by APW Wyott or its Authorized Service Agency. APW Wyott will only be responsible for charges incurred or service performed by its Authorized Service Agencies. The use of other than APW Wyott Authorized Service Agencies will void this warranty and APW Wyott will not be responsible for such work or any charges associated with same. The closest APW Wyott Authorized Service Agent must be used.

This warranty covers products shipped into the 48 contiguous United States, Hawaii, metropolitan areas of Alaska and Canada. There will be no labor coverage for equipment located on any island not connected by roadway to the mainland.

Warranty coverage on products used outside the 48 contiguous United States, Hawaii, and metropolitan areas of Alaska and Canada may vary. Contact the international APW Wyott distributor, dealer, or service agency for details.

Time Period

One year for parts and one year for labor, effective from the date of purchase by the original owner. The Authorized Service Agency may, at their option, require proof of purchase. Parts replaced under this warranty are warranted for the un-expired portion of the original product warranty only.

Exceptions

***Gas/Electric Cookline:** Models GCB, GCRB, GF, GGM, GGT, CHP-H, EF, EG, EHP. Three (3) Year Warranty on all component parts, except switches and thermostats. (2 additional years on parts only. No labor on second or third year.)

***Broiler Briquettes, Rock Grates, Cooking Grates, Burner Shields, Fireboxes:** 90 Day Material Only. No Labor.

***Heat Strips:** Models FD, FDL, FDD, FDDL. Two (2) Year Warranty on element only. No labor second year.

***Glass Windows, Doors, Seals, Rubber Seals, Light Bulbs:** 90 Day Material Only. No Labor.

In all cases, parts covered by extended warranty will be shipped FOB the factory after the first year.

Portable Carry In Products

Equipment weighing over 70 pounds or permanently installed will be serviced on-site as per the terms of this warranty. Equipment weighing 70 pounds or under, and which is not permanently installed, i.e. with cord and plug, is considered portable and is subject to the following warranty handling limitations. If portable equipment fails to operate in its intended manner on the first day of connection, or use, at APW Wyott's option or its Authorized Service Agency, it will be serviced on site or replaced.

From day two through the conclusion of this warranty period, portable units must be taken to or sent prepaid to the APW Wyott Authorized Service Agency for in-warranty repairs. No mileage or travel charges are allowed on portable units after the first day of use. If the customer wants on-site service, they may receive same by paying the travel and mileage charges. Exceptions to this rule: (1) countertop warmers and cookers, which are covered under the Enhanced Warranty Program, and (2) toasters or rollergrills which have in store service.

Exclusions

The following conditions are not covered by warranty:

*Equipment failure relating to improper installation, improper utility connection or supply and problems due to ventilation.

*Equipment that has not been properly maintained, calibration of controls, adjustments, damage from improper cleaning and water damage to controls.

*Equipment that has not been used in an appropriate manner, or has been subject to misuse or misapplication, neglect, abuse, accident, alteration, negligence, damage during transit, delivery or installation, fire, flood, riot or act of god.

*Equipment that has the model number or serial number removed or altered.

If the equipment has been changed, altered, modified or repaired by other than an Authorized Service Agency during or after the warranty period, then the manufacturer shall not be liable for any damages to any person or to any property, which may result from the use of the equipment thereafter.

This warranty does not cover services performed at overtime or premium labor rates. Should service be required at times which normally involve overtime or premium labor rates, the owner shall be charged for the difference between normal service rates and such premium rates. APW Wyott does not assume any liability for extended delays in replacing or repairing any items beyond its control.

In all cases, the use of other than APW Wyott Authorized OEM Replacement Parts will void this warranty.

This equipment is intended for commercial use only. Warranty is void if equipment is installed in other than commercial application.

Water Quality Requirements

Water supply intended for a unit that has in excess of 3.0 grains of hardness per gallon (GPG) must be treated or softened before being used. Water containing over 3.0 GPG will decrease the efficiency and reduce the operation life of the unit.

Note: Product failure caused by liming or sediment buildup is not covered under warranty.

"THE FOREGOING WARRANTY IS IN LIEU OF ANY AND ALL OTHER WARRANTIES EXPRESSED OR IMPLIED INCLUDING ANY IMPLIED WARRANTY OF MERCHANTABILITY OR FITNESS FOR PARTICULAR PURPOSES AND CONSTITUTES THE ENTIRE LIABILITY OF APW WYOTT. IN NO EVENT DOES THE LIMITED WARRANTY EXTEND BEYOND THE TERMS STATED HEREIN."

9/05



Phone: (214) 421-7366
Fax: (214) 565-0976
Toll Free: (800) 527-2100
Website: www.apwwyott.com
E-mail: info@apwwyott.com

APW WYOTT
729 Third Avenue
Dallas, TX 75226