



IMPORTANT FOR FUTURE REFERENCE

Please complete this information and retain this manual for the life of the equipment:

Model #: _____

Serial #: _____

Date Purchased: _____

INSTALLATION & OPERATION MANUAL

Direct Steam Full Jacketed Tilting Kettles DLT-20F DLT-30F DLT-40F DLT-60F

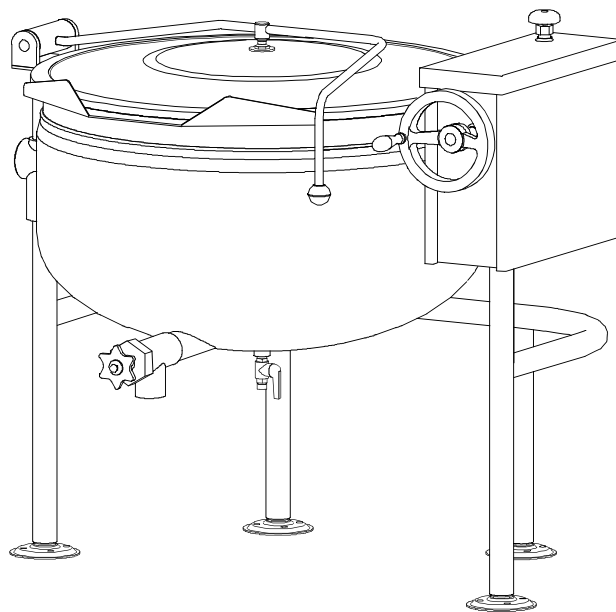

DLT-F

⚠ WARNING

Improper installation, adjustment, alteration, service or maintenance can cause property damage, injury or death. Read the installation, operating and maintenance instructions thoroughly before installing or servicing this equipment.

CROWN FOOD SERVICE EQUIPMENT

 A Middleby Company

70 Oakdale Road, Downsview (Toronto) Ontario, Canada, M3N 1V9

Telephone: 919-762-1000

www.crownsteamgroup.com

Printed in Canada



INSTALLATION AND OPERATION MANUAL, DIRECT STEAM FULL JACKET TILTING KETTLES,
MODELS: DLT-20F, DLT-30F, DLT-40F, DLT-60F

IMPORTANT NOTES FOR INSTALLATION AND OPERATION

It is recommended that this manual be read thoroughly and that all instructions be followed carefully.



This is the safety alert symbol. It is used to alert you to potential personal injury hazards. Obey all safety messages that follow this symbol to avoid possible injury or death.



WARNING: Improper installation, operation, adjustment, alteration, service or maintenance can cause property damage, injury or death. Read the installation, operating and maintenance instructions thoroughly before installing, operating or servicing this equipment.

Intended for commercial use only. Not for household use.

NOTICE: Contact the factory, the factory representative or local service company to perform maintenance and repairs.

This manual should be retained for future reference.

INSTALLATION AND OPERATION MANUAL, DIRECT STEAM FULL JACKET TILTING KETTLES,
MODELS: DLT-20F, DLT-30F, DLT-40F, DLT-60F

TABLE OF CONTENTS

DESCRIPTION	PAGE
SERVICE CONNECTIONS	4
1.0 INSTALLATION INSTRUCTIONS	5
2.0 INTRODUCTION - DESCRIPTION	6
3.0 OPERATING INSTRUCTIONS	7
4.0 CLEANING INSTRUCTIONS	8
5.0 MAINTENANCE	9
6.0 TROUBLESHOOTING	10

INSTALLATION AND OPERATION MANUAL, DIRECT STEAM FULL JACKET TILTING KETTLES, MODELS: DLT-20F, DLT-30F, DLT-40F, DLT-60F

SERVICE CONNECTIONS

☁ - Steam Supply: 3/4"IPS. Pressure reducing valve is required if incoming pressure exceeds jacket rating.

Ⓔ - CONDENSATE RETURN: 1/2"IPS

DIMENSIONS

MODEL	CAPACITY	UNITS	A	B	C	D	E	F	G	H(2")	H(3")	J(2")	J(3")	K	L	M
DLT-20F	20 gallons	inches	26	15.75	34.75	39.75	33.5	20.25	-	13	15.25	12.5	12	63	NONE	16.38
	76 litres	mm	660	400	883	1010	850	514	-	330	387	318	305	1600		416
DLT-30F	30 gallons	inches	29.5	17.5	34.5	43.25	37	21.5	-	15.5	15.5	14.5	14	65.63	9.5	18.38
	114 litres	mm	749	445	876	1100	940	546	-	394	394	368	356	1667	241	467
DLT-40F	40 gallons	inches	33	19.25	33.75	46.75	40.5	20	-	14.5	16.25	12.5	12	67.25	11	19.88
	152 litres	mm	840	489	857	1185	1030	508	-	368	413	318	305	1709	279	505
DLT-60F	60 gallons	inches	35.5	20.5	35	49.25	43	21	-	18	20.25	10.5	10	71.88	12.5	21.5
	227 litres	mm	902	521	889	1251	1092	533	-	457	514	267	254	1826	318	546

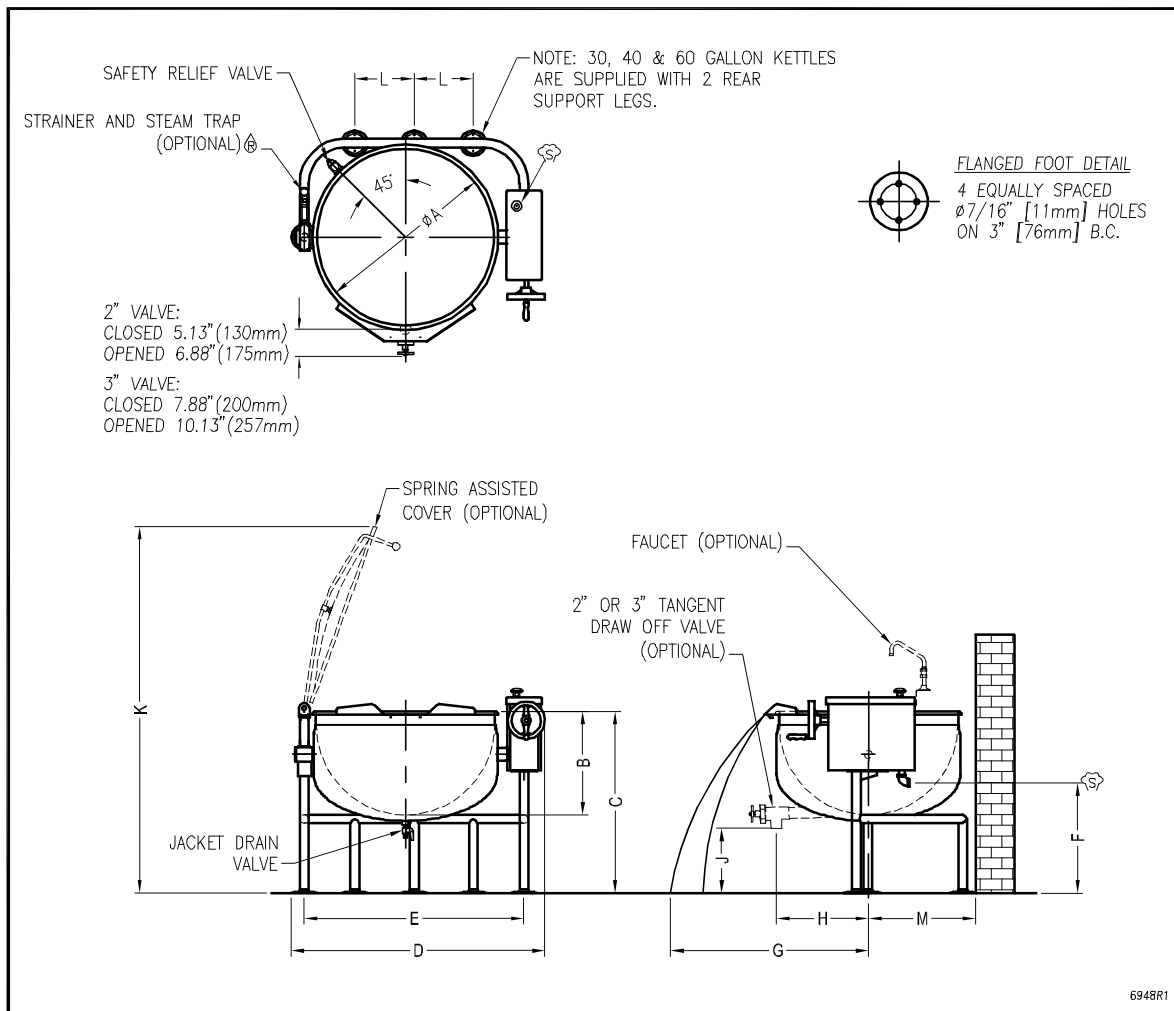

As continued product improvement is a policy of Crown, specifications are subject to change without notice.

INSTALLATION AND OPERATION MANUAL, DIRECT STEAM FULL JACKET TILTING KETTLES,
MODELS: DLT-20F, DLT-30F, DLT-40F, DLT-60F

1.0 INSTALLATION INSTRUCTIONS

1. Select a location to provide drainage for the kettle pour path when tilted and for the draw-off valve if so equipped.
2. Mark hole locations through flanged adjustable feet. Remove the kettle.
3. On hole locations marked, drill holes and insert expansion shields to accommodate 5/16" size lag bolts.
4. Reposition the kettle. Level the kettle by making necessary adjustment on flanged foot.
5. Bolt down kettle and seal with Silastic or other equivalent sealing compound. A sealant must be applied not only to bolt heads but also around flanges or pedestal base making contact with floor surface to fulfil NSF requirements.
6. Connect steam line (3/4" pipe size) to the kettle, making sure there is a steam control valve strainer fairly convenient to the kettle.
7. Connect kettle condensate return line to a drain or to a boiler return line. Each kettle return line must have a suitable steam trap. Boiler return lines must have a check valve.
8. The safety relief valve on the kettle must not be plugged as it is set to relieve excess pressure in the kettle.
9. If incoming steam pressure is greater than kettle maximum operation pressure then a pressure reducing valve must be installed in the line.
10. If large amounts of water accumulate in the steam line, it will be necessary to install one or more ball float traps in the line to eliminate the water.
11. A steam line pressure gauge is also recommended to determine the actual amount of steam being supplied to the kettle.
12. Check for proper operation.

INSTALLATION AND OPERATION MANUAL, DIRECT STEAM FULL JACKET TILTING KETTLES,
MODELS: DLT-20F, DLT-30F, DLT-40F, DLT-60F

2.0 INTRODUCTION - DESCRIPTION

All Crown direct connected steam jacketed kettles pertaining to this manual are direct steam operated pressure vessels of a double-wall stainless steel construction forming a steam chamber (jacket) enveloping of the kettle bowl surface. Kettle is tilting, floor mounted in fixed positions on legs with adjustable flanged feet. Kettle is equipped with a drain cock, safety relief valve and a steam control valve. Options on kettles include hinged spring assisted stainless steel lid covering the kettle bowl opening and a sanitary stainless steel tangent draw-off valve as an alternate method for the removal of the food product from the kettle bowl.

CAPACITIES

All models are suffixed with either - 20F, - 30F, - 40F or 60F to indicate the capacity of that kettle in U.S. gallons. Thus a DLT-40F is a full jacketed direct steam kettle mounted on legs with a capacity of 40 gallons (U.S.).

FUNCTIONING MODE

Crown direct connected steam jacketed kettles consist of a stainless steel bowl and a stainless steel jacket which envelopes the lower surface of the bowl thus forming a sealed pressure vessel (chamber) into which steam is introduced by means of a manual control valve.

The kettle bowl is the container for the food product which ideally should be of a liquid or semi-liquid consistency to achieve complete contact with the bowl surface and thus fully absorb the heat transmitted through the surface.

The temperature required for the cooking process to function adequately must be greater than the boiling point of the liquid food product. Further, the greater the steam pressure used, the higher the temperature and consequently the quicker the cooking process. For example, steam pressurized at 30 p.s.i. attains a temperature of 274 degrees Fahrenheit (135 degrees Celsius).

INSTALLATION AND OPERATION MANUAL, DIRECT STEAM FULL JACKET TILTING KETTLES,
MODELS: DLT-20F, DLT-30F, DLT-40F, DLT-60F

3.0 OPERATING INSTRUCTIONS

1. If the kettle has draw-off valve, close it.
2. Fill the kettle with a product to desired level.
3. Slowly turn the steam control valve ON to full open position (counterclockwise).
4. The kettle should boil two to three gallons of water per minute. If it does not then incoming pressure and piping should be checked to determine that it is adequate to operate the kettle efficiently.
5. Regulate steam control valve depending on type of food being prepared.
6. When food is cooked, turn off steam, remove food and clean the kettle immediately to prevent residue from drying on the kettle bowl surface.

4.0 CLEANING INSTRUCTIONS

Your kettle should be cleaned immediately after each use.

1. Ensure that steam supply is OFF.
2. Pre-rinse inside of the kettle thoroughly and drain to remove any food particles.
3. Using a nylon brush, clean the kettle with a mild detergent and warm water rinse. Never use steel wool or scouring powder as it will scratch stainless steel.
4. Tilt the kettle fully or open the tangent draw-off valve if one is provided to allow soap and water solution to drain. Rinse with clean water.
5. On kettles equipped with a draw-off valve, turn the large hex nut counterclockwise by hand until it is completely disengaged from the thread. Grasp the knob to valve and slowly pull out valve stem and disc. Do not allow the disc to come in contact with hard surfaces since damage to disc may occur and result in valve leakage. Wash the valve stem, disc and handle. Insert nylon brush with detergent into interior of valve body and tangent draw-off tube and brush vigorously. Replace valve stem assembly and engage the hex nut fully by hand. Flush the kettle with clean warm water. Leave the valve open when the kettle is not in use.

INSTALLATION AND OPERATION MANUAL, DIRECT STEAM FULL JACKET TILTING KETTLES,
MODELS: DLT-20F, DLT-30F, DLT-40F, DLT-60F

4.0 CLEANING INSTRUCTIONS (Continued)

	CAUTION: Do not use cleaning agents that are corrosive.
---	--

Use of cleaning agents that contain chloride, acids or salts are corrosive and may cause pitting and corrosion when used over a period of time; this will reduce the life of the appliance.

Pitting or corrosion is not covered by warranty.

Follow the recommended cleaning instructions. Use a mild detergent, warm water and rinse thoroughly.

5.0 MAINTENANCE

SAFETY VALVE MAINTENANCE AND TESTING

	<p>CAUTION! Under normal operating conditions a “try lever test” should be performed every two months. Under severe service conditions, or if corrosion and/or deposits are noticed within the valve body, testing must be performed more often. A “try lever test” should also be performed at the end of any non-service period.</p>
---	---

	<p>CAUTION! Hot, high pressure fluid may be discharged from body drain and vent during “try lever” test. Care must be taken to avoid any bodily contact.</p>
---	---

	<p>CAUTION! High sound levels may be experienced during “try lever” test. Wear proper safety equipment and exercise extreme care! Test at, or near, half of the operating pressure by holding the test lever fully open for at least two seconds to flush the valve seat free of sediment and debris. Then release lever and permit the valve to snap shut.</p> <p>If lift lever does not activate, or there is no evidence of discharge, turn off equipment immediately and contact a licensed contractor or qualified service personnel.</p>
---	---

6.0 TROUBLESHOOTING

DRAW-OFF VALVE LEAKS

If a leak occurs through the valve stem, replace the "O" ring. If the leak can be attributed to faulty sealing occurring between the stem disc and valve seat, then quite often this problem can be corrected by cleaning off the dried on food residue with an extremely fine emery cloth or the rubber vulcanized stem piece has been damaged and must be replaced.

NOTICE: Draw-off valve has a vulcanized rubber coated stem for better sealing. Do not over tighten. This may cause the rubber to pull away from stem and permanently damage it.

EXTREMELY SLOW COOKING TIME

If the cooking time is abnormally slow then the difficulty may be due to insufficient steam pressure and/or volume. First determine that pressure on incoming steam line at the kettle is within 5 p.s.i. of rated kettle pressure. Note that pressures approaching the rated kettle pressure are liable to set off the safety relief valve. If required pressure is available to the kettle, then possibly volume of steam is not sufficient. Minimum 3/4" pipe size is required to the kettle but if the steam generating source is at a great distance from the kettle, larger pipe will be required. Finally, the core of the steam supply pipe may have debris or scalants that impede steam flow and will require disassembly and inspection.

AIR VENTING

It is recommended that the "optional" steam trap assembly be installed. This should be plumbed to the exit end of the kettle. The thermostatic trap is a mechanical device that closes on high temperature and opens when the temperature drops, allowing the water which formed from condensate to exhaust but retain the steam under pressure.

The temperatures required for the cooking process to function adequately must be greater than the boiling point of the liquid food product, that is, water. The greater the steam pressure used, the higher the temperature and the quicker the cooking process. For example, steam pressurized at 30 psi reaches a temperature of 274 degrees Fahrenheit (135 degrees Celsius). Since air is an unsuitable media through which heat may be transferred, the air should be exhausted from the jacket by opening the pressure relief valve until the air has been completely replaced by pressurized steam.

INSTALLATION AND OPERATION MANUAL, DIRECT STEAM FULL JACKET TILTING KETTLES,
MODELS: DLT-20F, DLT-30F, DLT-40F, DLT-60F

6.0 TROUBLESHOOTING (Continued)

AIR VENTING (Continued)

In the initial stages of the cooking process when the steam comes in contact with the cold kettle bowl surface, it condenses and forms a large amount of water. The condensate water must be removed from the kettle jacket in order for the kettle to function adequately. The ball valve located at the base of the kettle jacket may be opened to remove the water. It may be necessary to repeat this procedure several times depending on the number of batches being cooked as each batch will create condensate. If the kettle appears to be slow in heating, this would indicate that there is water in the jacket. Open ball valve and drain. Close valve and commence operation of the kettle.