

Parts Catalogue

Chefmate
by Globe

Chefmate
by Globe

Chefmate
by Globe

Chefmate
by Globe

Chefmate
by Globe



Model GCM20H

MIXERS

MODEL: GCM20, GCM20H, GCM20HF

1-1-2002

IMPORTANT!

TO EXPEDITE SHIPMENT OF PARTS, ALWAYS SPECIFY MODEL, REV,
PART NUMBER, AND SERIAL NUMBER OF MIXER.

GLOBE FOOD EQUIPMENT COMPANY

2268 N. Moraine Drive

Dayton, Ohio 45439

Parts Department

Toll Free 1-800-745-6238 • Fax (937) 290-0585

E-Mail: globeinfo@globeslicers.com

Website: www.globeslicers.com

Not for resale

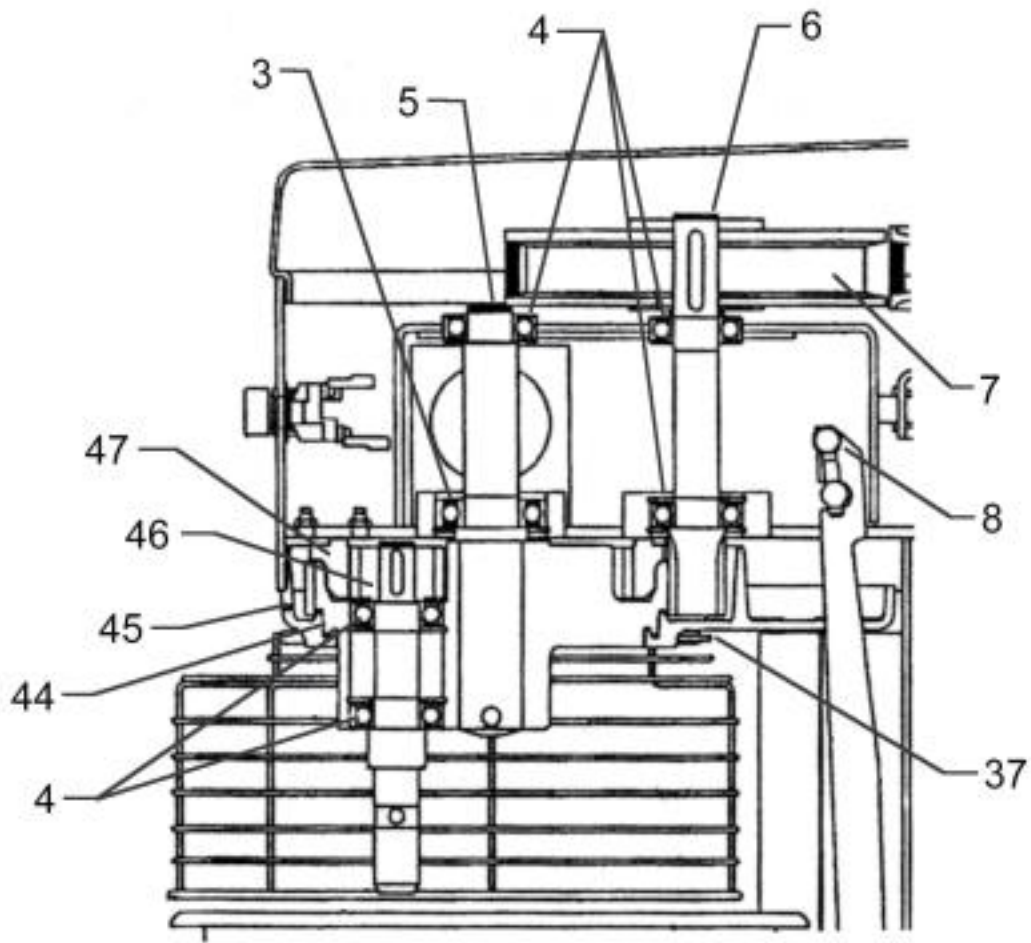

3.	BALL BEARINGS	X01181
4.	BALL BEARINGS	X01180
5.	PLANETARY SHAFT	X01054
6.	DRIVE SHAFT	X01075
7.	DRIVE PULLEY	X01053
8.	BOWL LIFT ROD	X01203
37.	MICRO SWITCH(GAURD)	X01245
44.	PLANETARY	X01074
45.	GEAR COVER	X01061
46.	PLANETARY GEAR	X01056
47.	INTERNAL TOOTHED CROWN	X01056

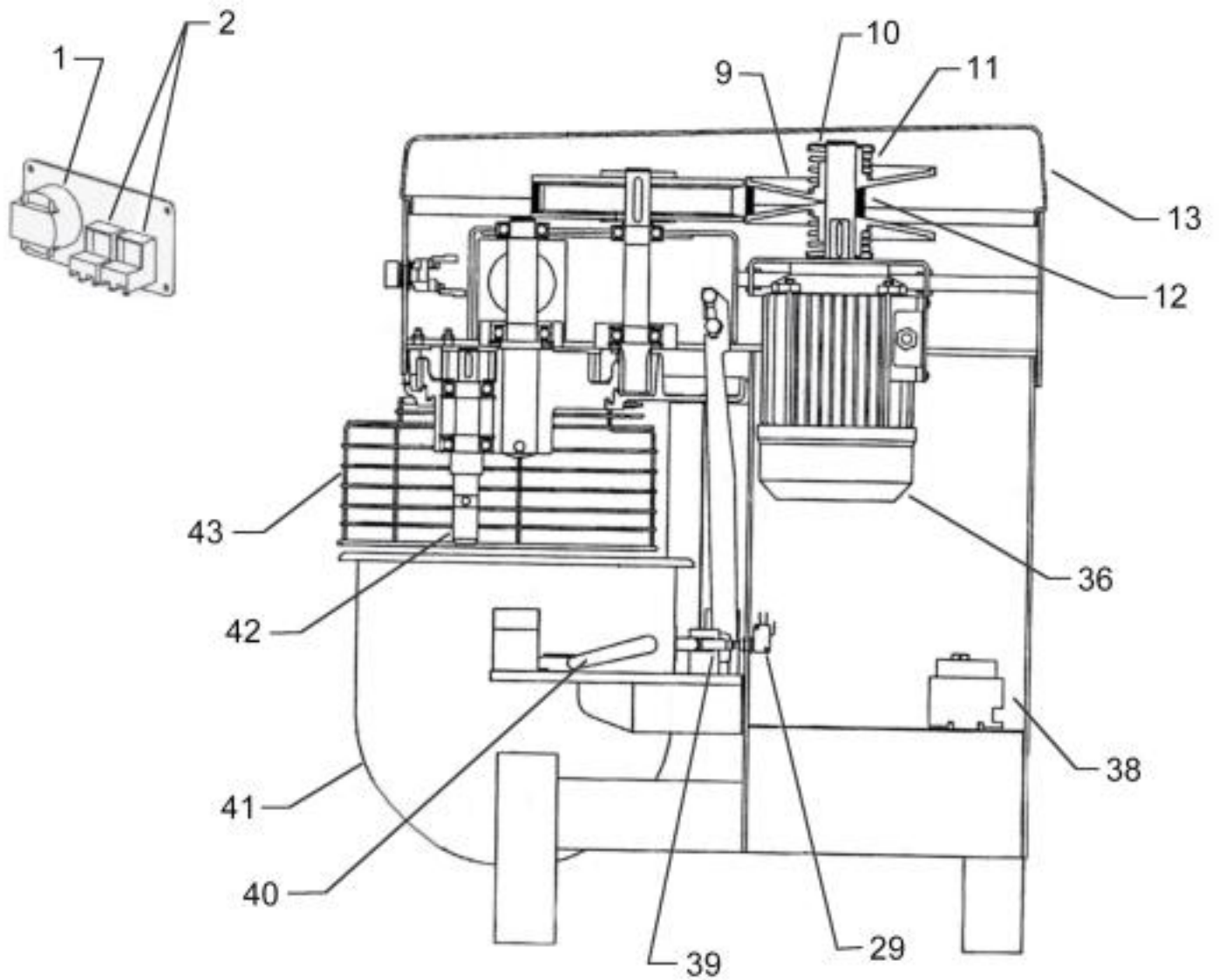

1a.	TIMER KNOB	X01214
b.	TIMER	X01215
2a.	START BUTTON	X01216
b.	STOP SWITCH	X01217
c.	START SWITCH	X01218
d.	RED STOP BUTTON	X01234
9.	VARIATOR GROUP	X01230
10.	SPRING RETAINER	●
11.	PULLEY HALF	●
12.	BELT	X01076
13.	TOP COVER	X01149
29.	BOWL SAFETY	X01229
36.	MOTOR	X01175
38.	CONTACTOR	X01212
39.	BOWL PRESENCE PIN	X01073
40.	LOCATING HANDLE	X01247
41.	BOWL	NA
42.	TOOL SHAFT	X01057
43.	BOWL GAURD	X01053

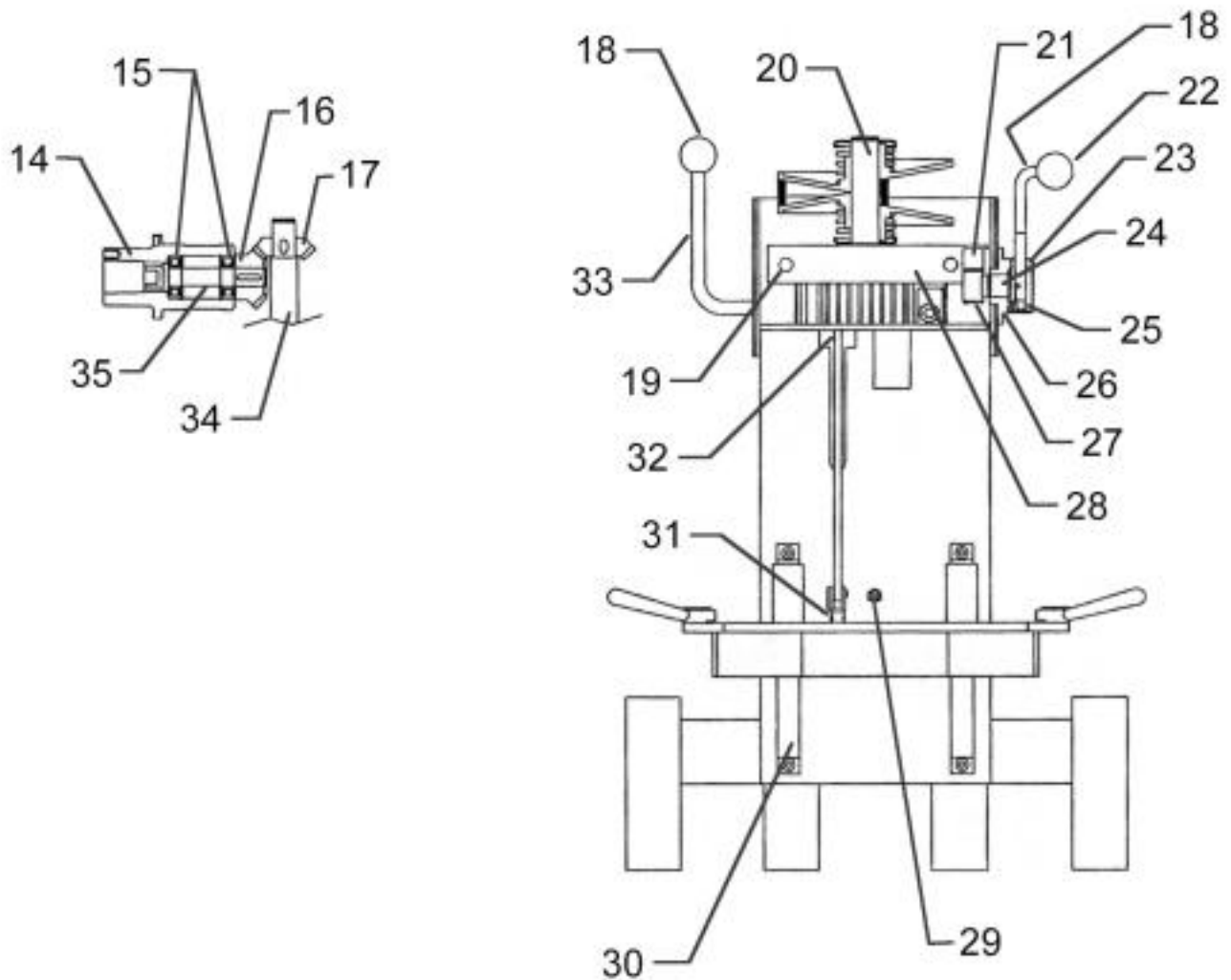

14.	STAY FOR REDUCER	X01059
15.	BALL BEARINGS (2 REQ.)	X01179
16.	BEVEL GEAR PAIR	X01068
17.	BEVEL GEAR	X01058
18.	KNOB (2 REQ.)	X01189
19.	BARS FOR CHAIR	X01080
20.	PULLEY SHAFT	X01082
21.	RACK POLE	X01067
22.	SPEED SELECT LEVER	X01025
23.	HANDLE SPRING	X01084, X01165
24.	SPEED PIN	X01065
25.	COVER	X01165
26.	SPEED LEVER SUPPORT	X01072
27.	TOOTHED WHEEL	X01066
28.	MOTOR CHAIR	X01144
30.	BOWL LIFT POLES	X01064
31.	CLIP PIN, SMALL FORK	X01205, X01246
32.	BOWL LIFT CONNECTING ROD	X01063
33.	BOWL LIFT LEVER	X01062
34.	PLANETARY SHAFT FOR REDUCER	X01054
35.	SHAFT HUB FOR REDUCER	X01060

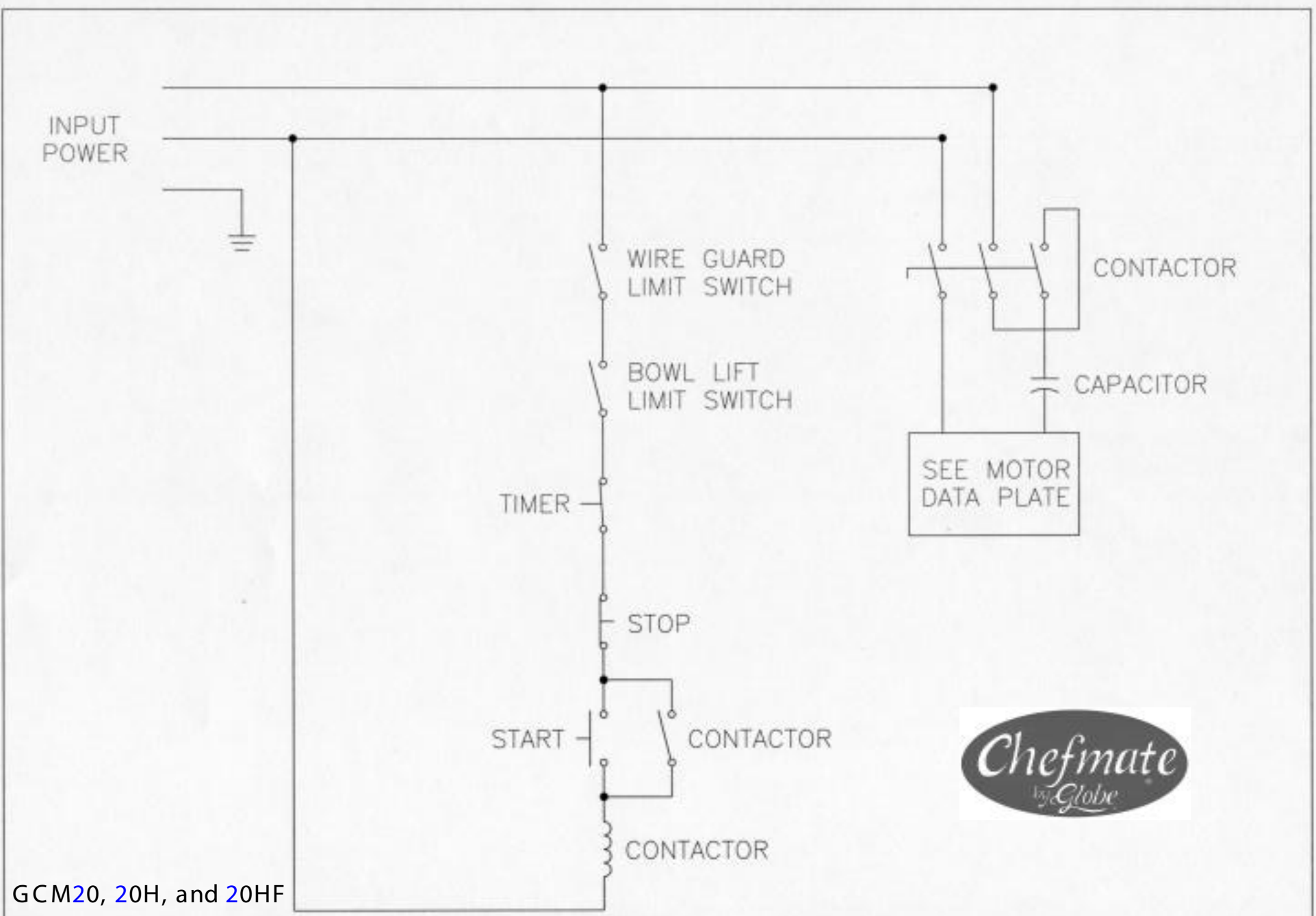

GCM20, 20H, and 20HF



PLANETARY MIXER – SINGLE PHASE