

Parts Catalog



S13A-15

S-Series Slicer **Standard Automatic Correctional Package** **Model: S13A-15**

5/25/2021 Rev. V

IMPORTANT!

TO EXPEDITE SHIPMENT OF PARTS, ALWAYS SPECIFY MODEL, REV,
PART NUMBER, AND SERIAL NUMBER OF UNIT.

GLOBE FOOD EQUIPMENT COMPANY

2215 East River Road
Dayton, Ohio 45439

Parts Department

Toll Free 1-800-745-6238 · Fax (937) 290-0585

E-Mail: info@globefoodequip.com

Website: www.globefoodequip.com

Not for resale

Table of Contents

Description	Page
S13A-15 Knife Drive Assembly Components	4
S13A-15 Index Knob Components	6
S13A-15 Base Shroud Components	8
S13A-15 Gauge Plate Components	10
S13A-15 Auto Engage Lever Components	12
S13A-15 Index Slide Assembly Components	14
S13A-15 Ring Guard Assembly Components	16
S13A-15 Electrical Base Components	18
S13A-15 Knife Drive Motor Components	22
S13A-15 Transport Arm Assembly Components	24
S13A-15 Automatic Drive Assembly Components	28
S13A-15 Automatic Lift Lever Base Components	30
S13A-15 Carriage and End Weight Assembly Components	32
S13A-15 Knife and Knife Cover Components	34
S13A-15 Dummy Sharpener Assembly	36
S13A-15 Wiring Schematic	38



S13A-15 Knife Drive Assembly Components

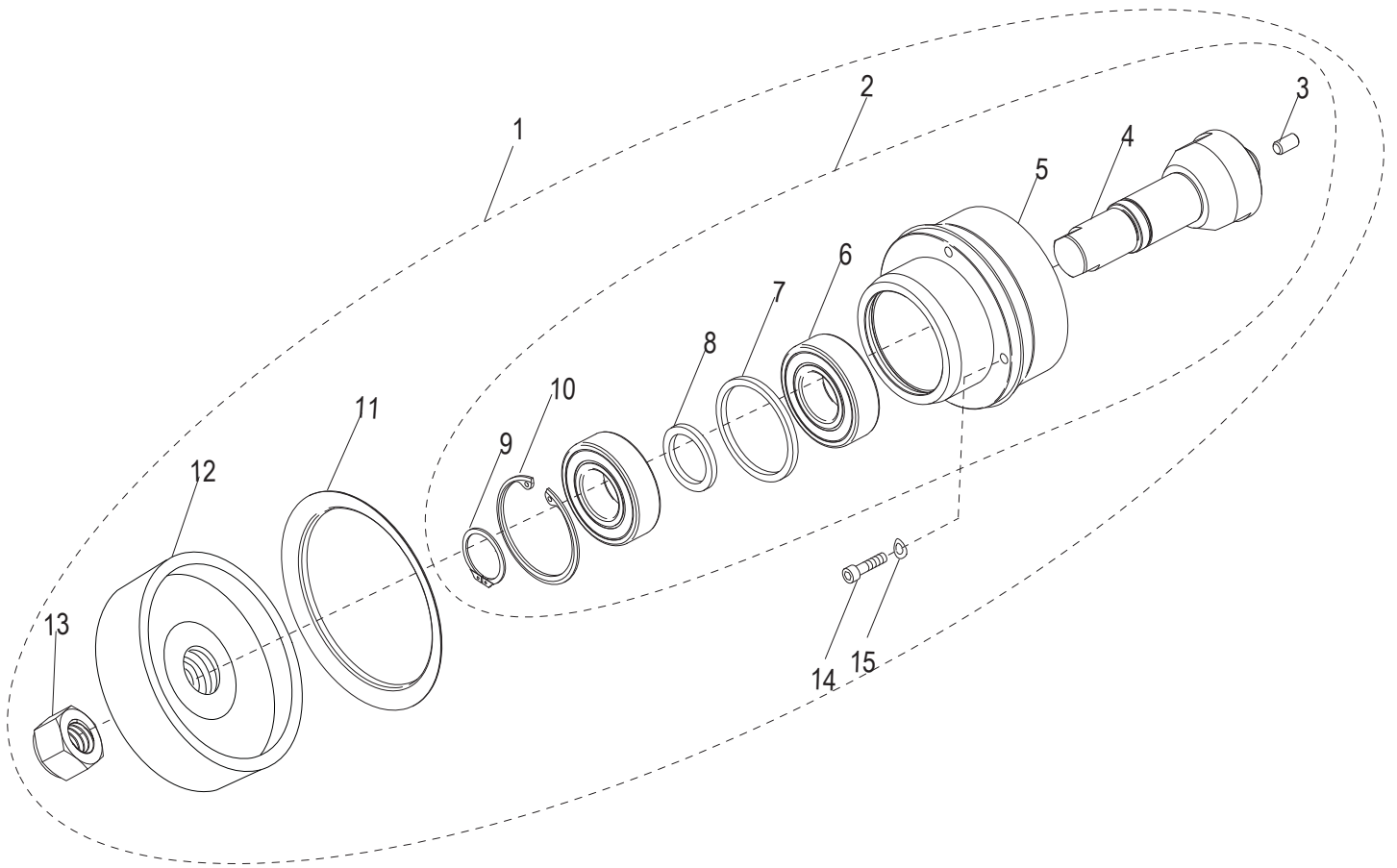



S13A-15 Knife Drive Assembly Components

Item	Part Number	Description	Qty	Serial Number
1	450211	Knife Drive Assembly (Incl. items 2-15)	1	
2	420088	Knife Drive Bearing Assembly (Incl. items 3-10)	1	
3	510078	Knife Cover Bumper	1	
4		Shaft, Knife Drive	1	
5		Knife Drive Bearing Mount	1	
6		Ball Bearing, Sealed	2	
7		Outer Ring, Bearing Spacer	1	
8		Inner Ring, Bearing Spacer	1	
9		Retaining Ring 5101-98 Bowed External	1	
10		Retaining Ring N5002-200	1	
11	520244	Knife Drive Boot	1	
12	450115	Knife Drive Pulley	1	
13	510033	Nut 7/8-20 Hex (Zinc)	1	
14	810229	Socket Hd. 1/4-20x3/4 Cap Screw, SST	4	
15	810275	Bellville Disc Spring Washer .255 ID x .50 OD	4	



S13A-15 Index Knob Components

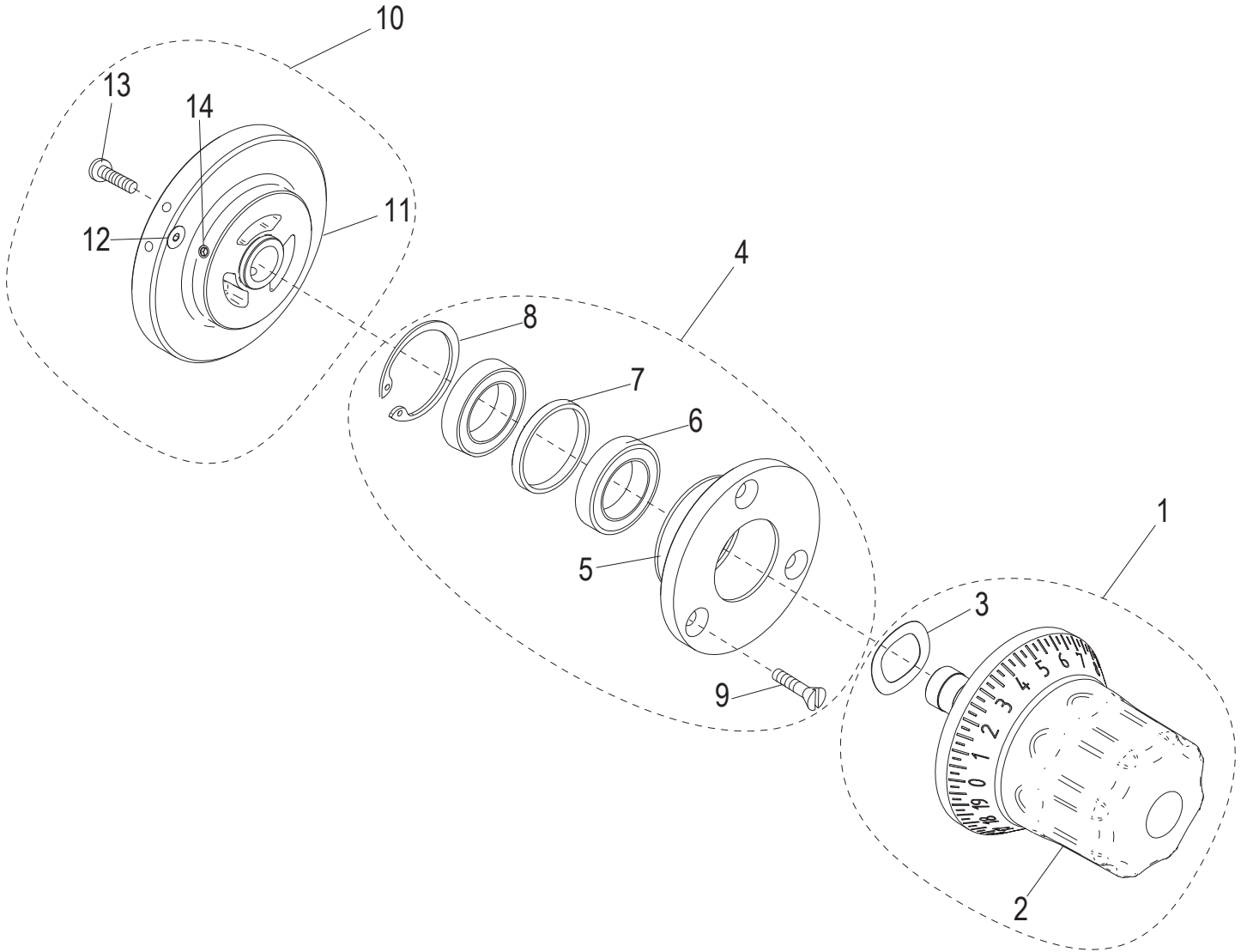



S13A-15 Index Knob Components

Item	Part Number	Description	Qty	Serial Number
1	500044	Index Knob Assembly (Incl. items 2-3)	1	
2	500022	Index Knob	1	
3	800136	Index Knob Tension Spring	1	
4	450214	Index Bearing Hub Assembly Kit (Incl. items 5-9)	1	
5		Index Knob Bearing Hub	1	
6		Index Knob Bearing	2	
7		Spacer, Index Bearing	1	
8		Beveled Retaining Ring	1	
9	800104	Mach. Screw #10-24x5/8 Flat Hd Slotted	3	
10	500050	Index Cam Assembly (Incl. items 11-16)	1	
11	520350	Index Cam	1	
12	800105	Socket Cap Screw #10-32x5/8 Button-Hd	1	
13		Socket Cap Screw #10-32x3/4 Flat Hd (SS)	1	
14		Set Screw, Knurl Grip Cup Pt 1/4-28x3/4 (SST)	3	



S13A-15 Base Shroud Components

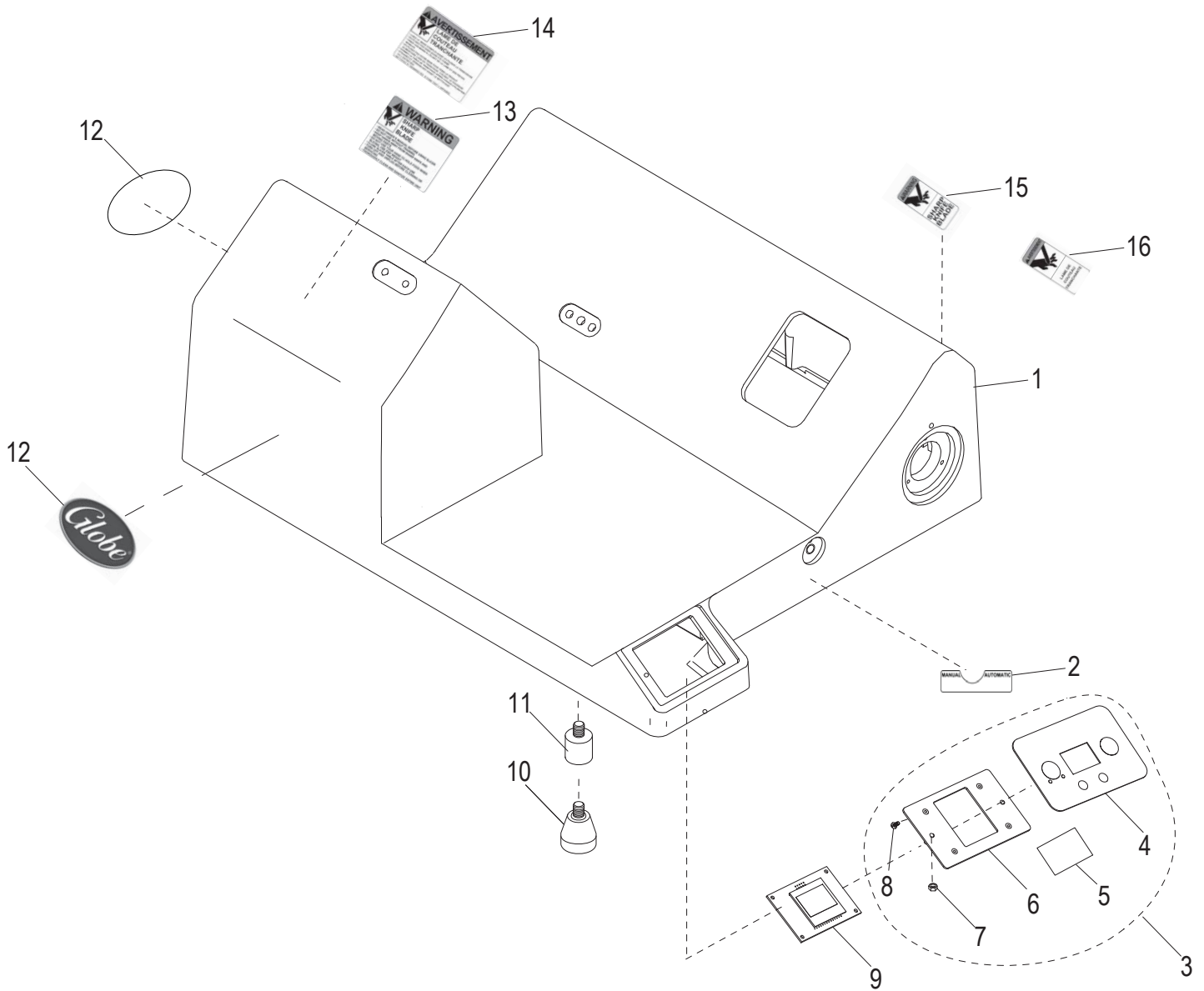



S13A-15 Base Shroud Components

Item	Part Number	Description	Qty	Serial Number
1		Slicer Base	1	
2	920203	Auto Engage Label	1	
3	121072	Membrane Switch Kit (Incl. items 4-8)	1	
4		Membrane Switch, Automatic Slicer	1	
5	910088	Pad, Alcohol Prep	1	
6		User Interface Panel, Smart/Auto	1	
7	810422	Nylon Locknut 6-32	2	
8	810423	Mach. Screw #4-40 x 1/4, 18-8 PH Cr (SST)	4	
9	121062	Display Assembly	1	
10	510031	Slicer Foot	4	
11	400158	Foot Extension	4	
12	920202	Globe Logo Decal, S-Series	2	
13	920200	Warning Label, Large	1	
14	920198	Warning Label, Large French	1	
15	920201	Warning Label, Small	1	
16	920199	Warning Label, Small French	1	



S13A-15 Gauge Plate Components

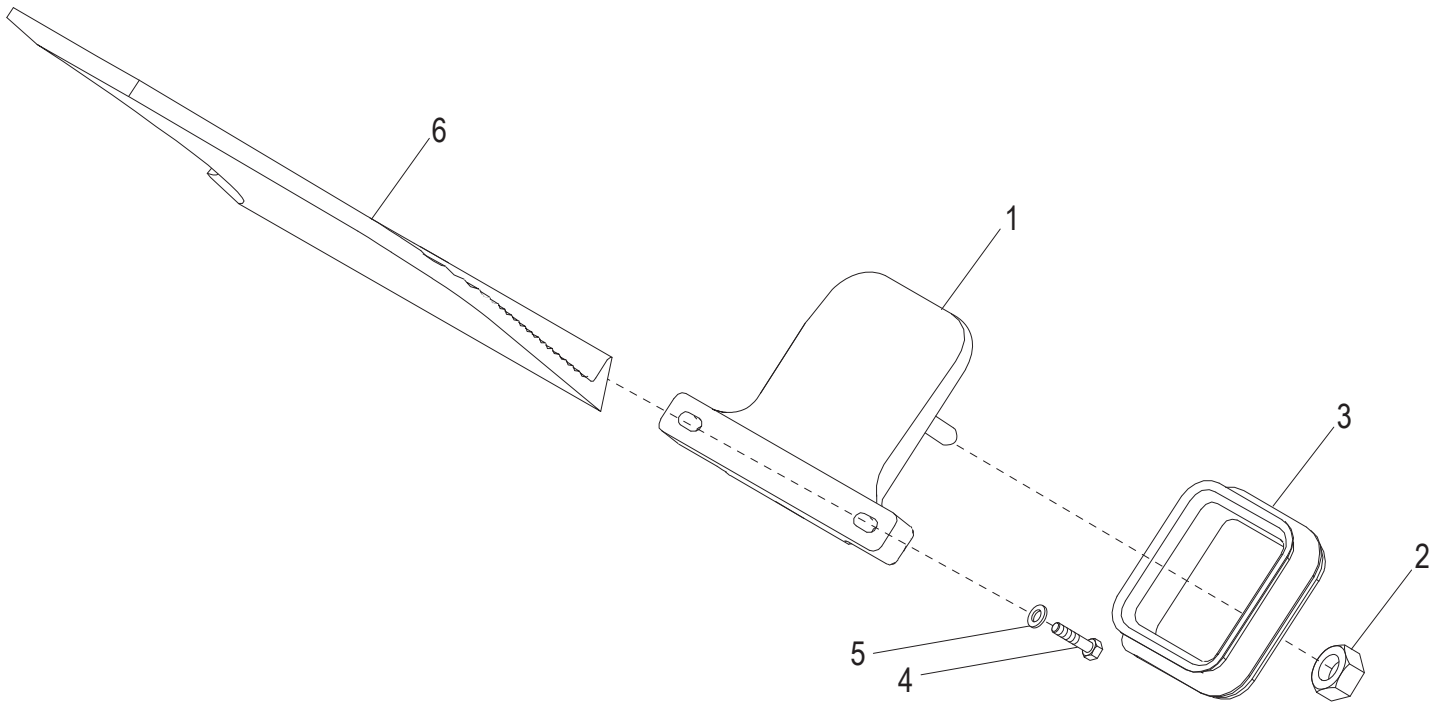



S13A-15 Gauge Plate Components

Item	Part Number	Description	Qty	Serial Number
1	450212	Gauge Plate Base Assembly	1	
2	450054	Post Nut, Gauge Plate Ball Joint	1	
3	500001	Gauge Plate Seal	1	
4	890411	Cap Screw 3/8-16x1-1/2, Hex Hd with Nylon Patch	2	
5	810228	Flat Washer, fits 3/8 Screw, .885 OD	2	
6	450070	Gauge Plate	1	



S13A-15 Auto Engage Lever Components

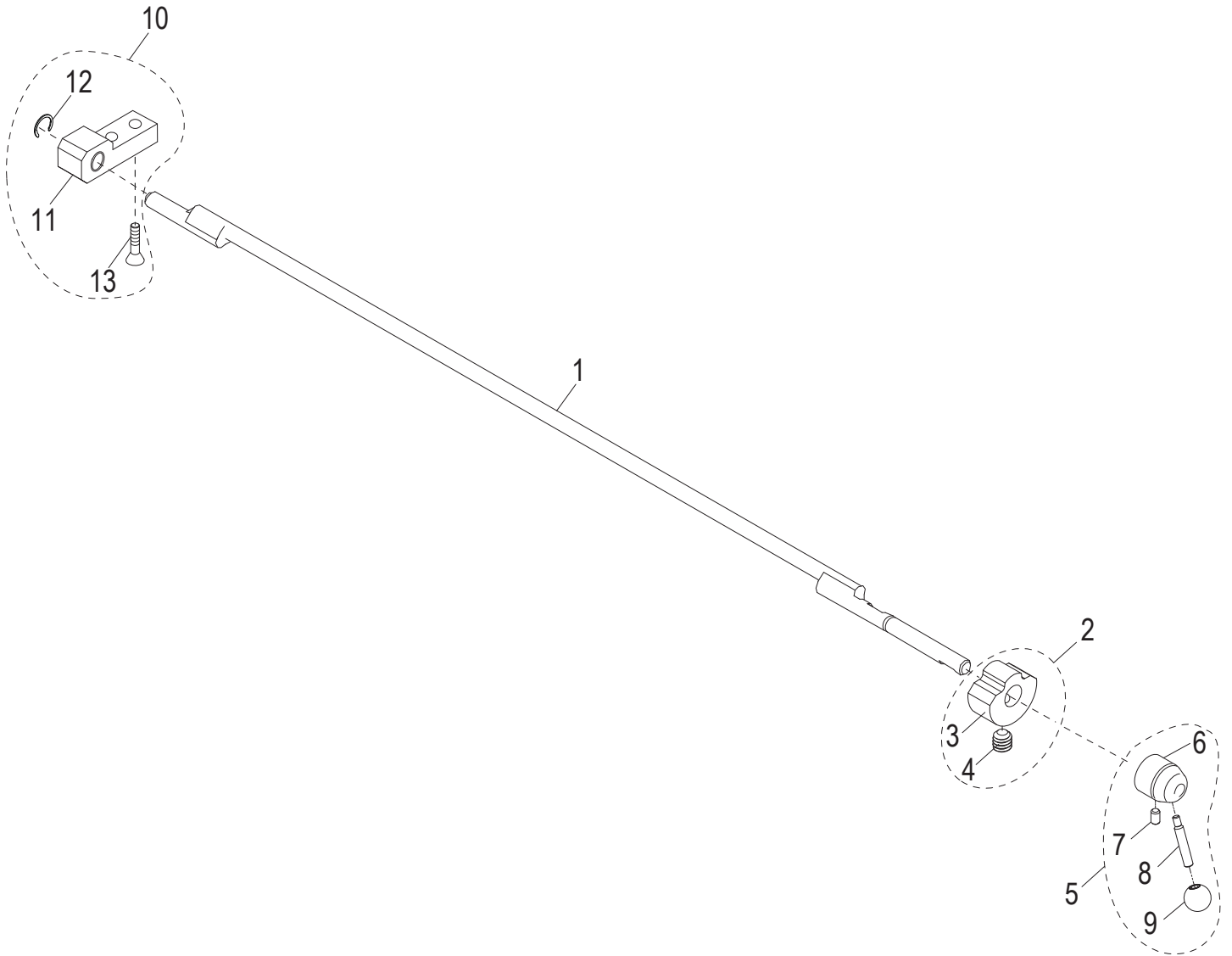



S13A-15 Auto Engage Lever Components

Item	Part Number	Description	Qty	Serial Number
1	400021	Auto Engage Assembly Bar	1	
2	400038	Position Block Assembly (Incl. items 3-4)	1	
3		Auto Engage Position Block	1	
4		Socket Set Screw 1/4-20x1/4, 18-8 Cup Pt. (SST)	1	
5	500029	Auto Engage Lever Assembly (Incl. items 6-9)	1	
6		Auto Engage Lever Hub	1	
7		Set Screw 1/4-20x.42 Cup Point	1	
8		Handle Shaft	1	
9		Auto Engage Handle Knob	1	
10	400126	Bearing Block Assembly Kit (Incl. items 11-13)	1	
11		Bearing Block Assembly	1	
12	810429	Retaining Ring, 5304-31 (Klipring)	1	
13	810003	Screw 1/4-20x3/4 Crossed Rec., Flat Hd, Tapping	2	



S13A-15 Index Slide Assembly Components

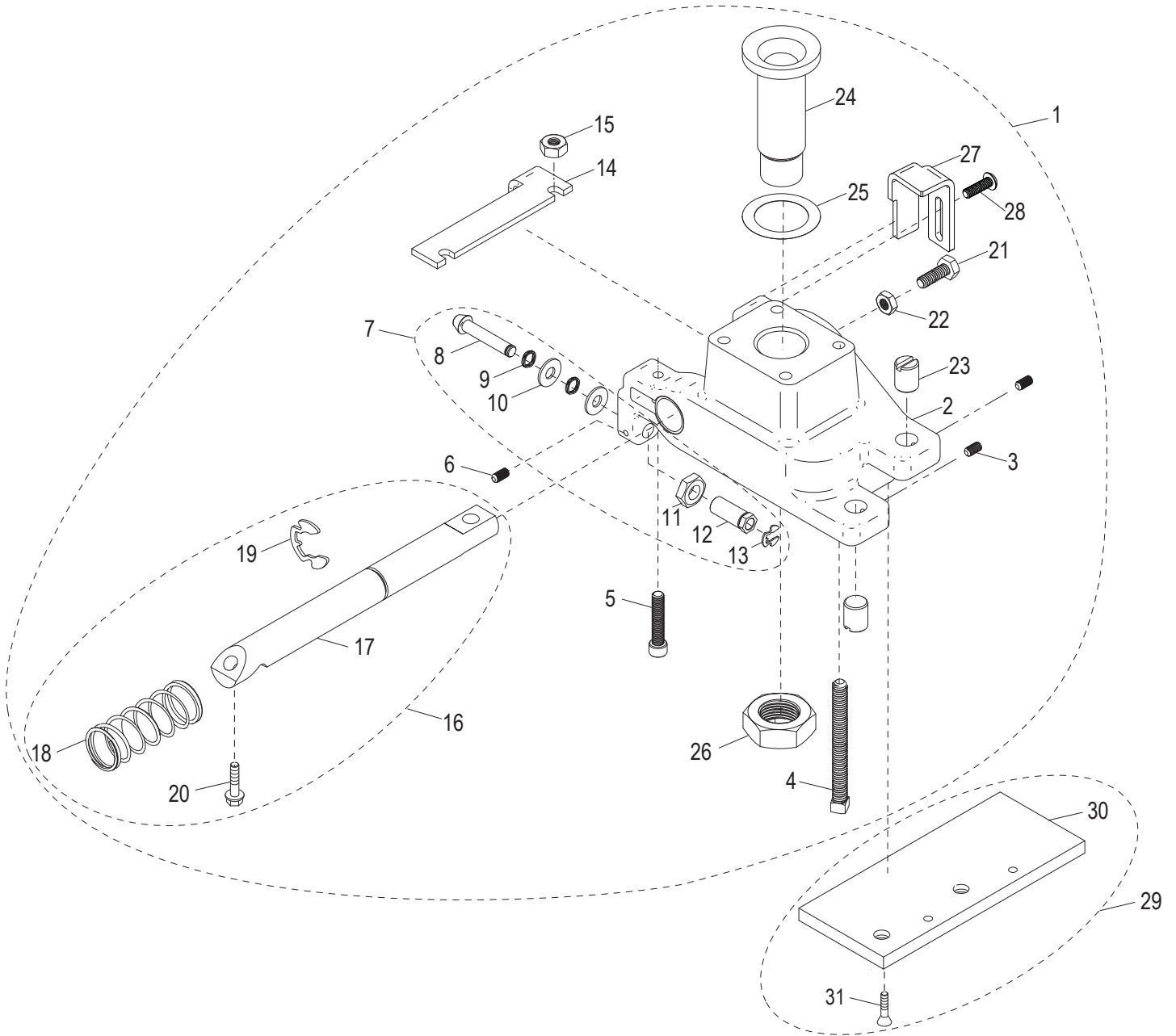



S13A-15 Index Slide Assembly Components

Item	Part Number	Description	Qty	Serial Number
1	400140	Index Slide Kit (Incl. items 1-28)	1	
2		Index Slide with Bushings	1	
3	810400	Set Screw #10-32x3/8 Cup Pt.	2	
4	800146	Set Screw 5/16-18x3 Sq. Hd Cup Point	4	
5	800144	Cap Screw 1/4-28x1-1/4 Socket Hd	2	
6	800091	Set Screw #8-32 x 3/16 Knurled Grip - Cup Pt.	1	
7	400121	Cam Follower Kit (Incl. items 8-13)	1	
8		Follower	1	
9		Wave Spring Cam Follower	2	
10		Flat Washer .266 ID, .625 OD Type A	1	
11	890390	Jam Nut 3/8-24 Sharpener Wheel	1	
12		Follower Adjustment Post	1	
13	810379	Retaining Clip Ring 5304-18	1	
14		Stop Plate, Tilt Back	1	
15	800145	Nut 1/4-28 Hex	2	
16	400122	Index Slide Shaft Kit (Incl. items 17-20)	1	
17		Index Slide Shaft	1	
18		Index Spring	1	
19	800152	Retaining Ring (Klipring) 5304-75	1	
20	800058	Washer 5/16-18-1 Hex Hd Tapping Screw	2	
21	810431	Cap Screw 1/4-20 x 3/4 Hex Hd	1	
22	810432	Nut, Thin 1/4-20 Hex	1	
23	450057	Screw, Anti-Rotation	2	
24	450050	Ball Joint Rest	1	
25	800168	Gauge Plate Spacer Kit (Kit of 4)	1	
26	800043	Nut 7/8-14 UNF Hex Jam	1	
27	300154	Adjustment Stop	1	
28	800105	Socket Cap Screw #10-32x5/8 Button-Hd	2	
29	400128	Anti-Rotation Plate Kit (Incl. items 29-31)	1	
30		Anti-Rotation Plate	1	
31	810003	Screw 1/4-20x3/4 Crossed Rec., Flat Hd, Tapping	2	



S13A-15 Ring Guard Assembly Components

Item 1
Ring Guard
Assembly

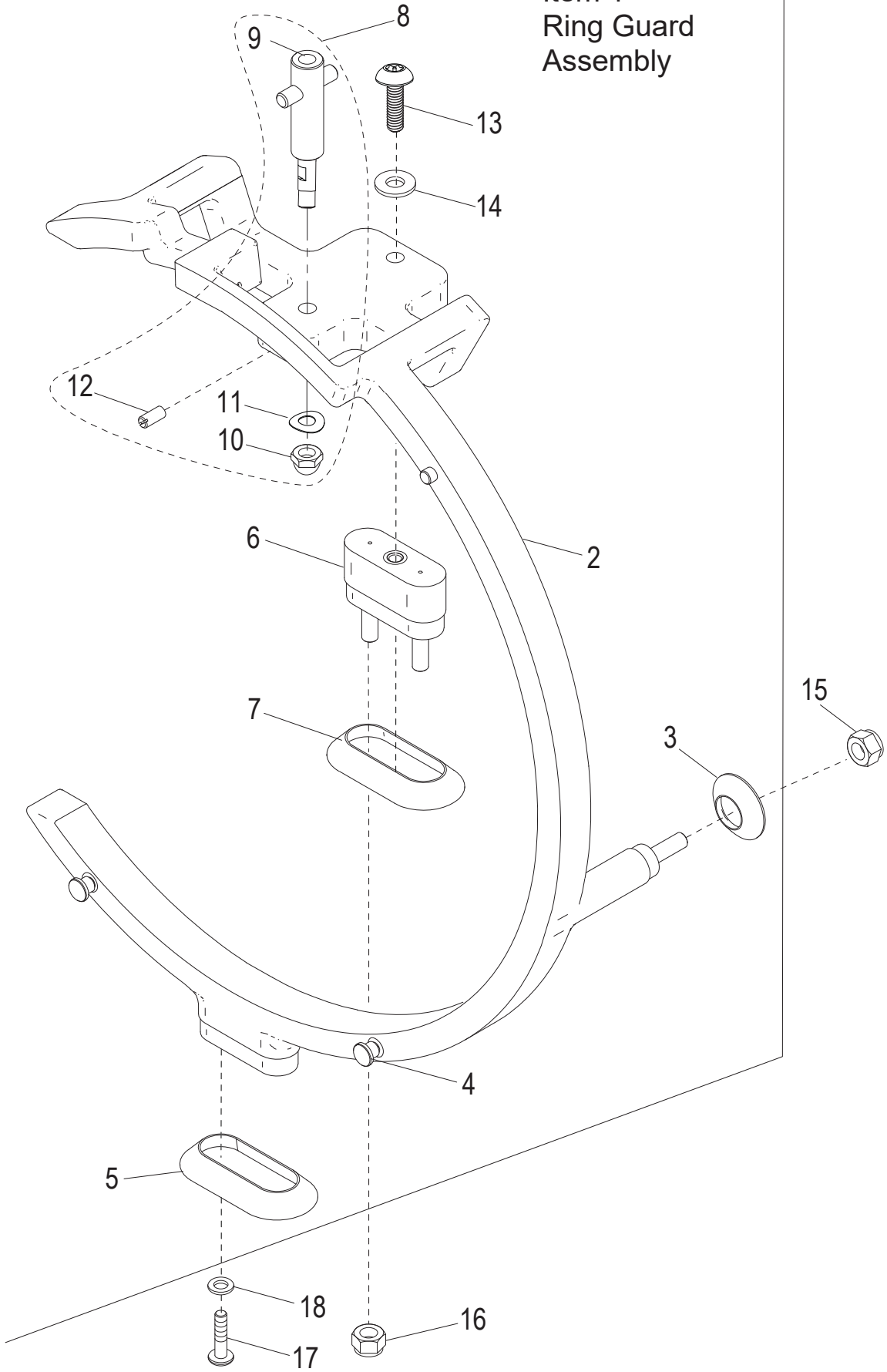



S13A-15 Ring Guard Assembly Components

Item	Part Number	Description	Qty	Serial Number
1	510085	Ring Guard Assembly (Incl. items 2-14)	1	
2	520316	Ring Guard	1	
3	520243	Round Boot, Ring Guard	1	
4	450130	Locator Pin	2	
5	520242	Oval Boot, Ring Guard	1	
6	460064	Spacer, Ring Guard	1	
7	520242	Oval Boot, Ring Guard	1	
8	460070	Sharpener Mount Assembly Kit (Incl. items 9-12)	1	
9		Sharpener Mount Assembly	1	
10	800185	Acorn Nut, 1/4-28 SST	1	
11	800184	Curved Disk Spring, 1/4" Rod Size	1	
12	810483	Slotted Set Screw 10-32	1	
13	810374	Mach. Screw 1/4-20x1, Torx	1	
14	810345	Flat Washer 1/4 Screw Thread (18-8 SST)	2	
15	810438	Nylon-Insert Nut 1/4-20 Grade 5 Stl Zinc Plated	1	
16	810438	Nylon-Insert Nut 1/4-20 Grade 5 Stl Zinc Plated	2	
17	810358	Mach. Screw 1/4-20x1 Truss Hd Slotted	2	
18	810345	Flat Washer 1/4 Screw Thread (18-8 SST)	1	



S13A-15 Electrical Base Components

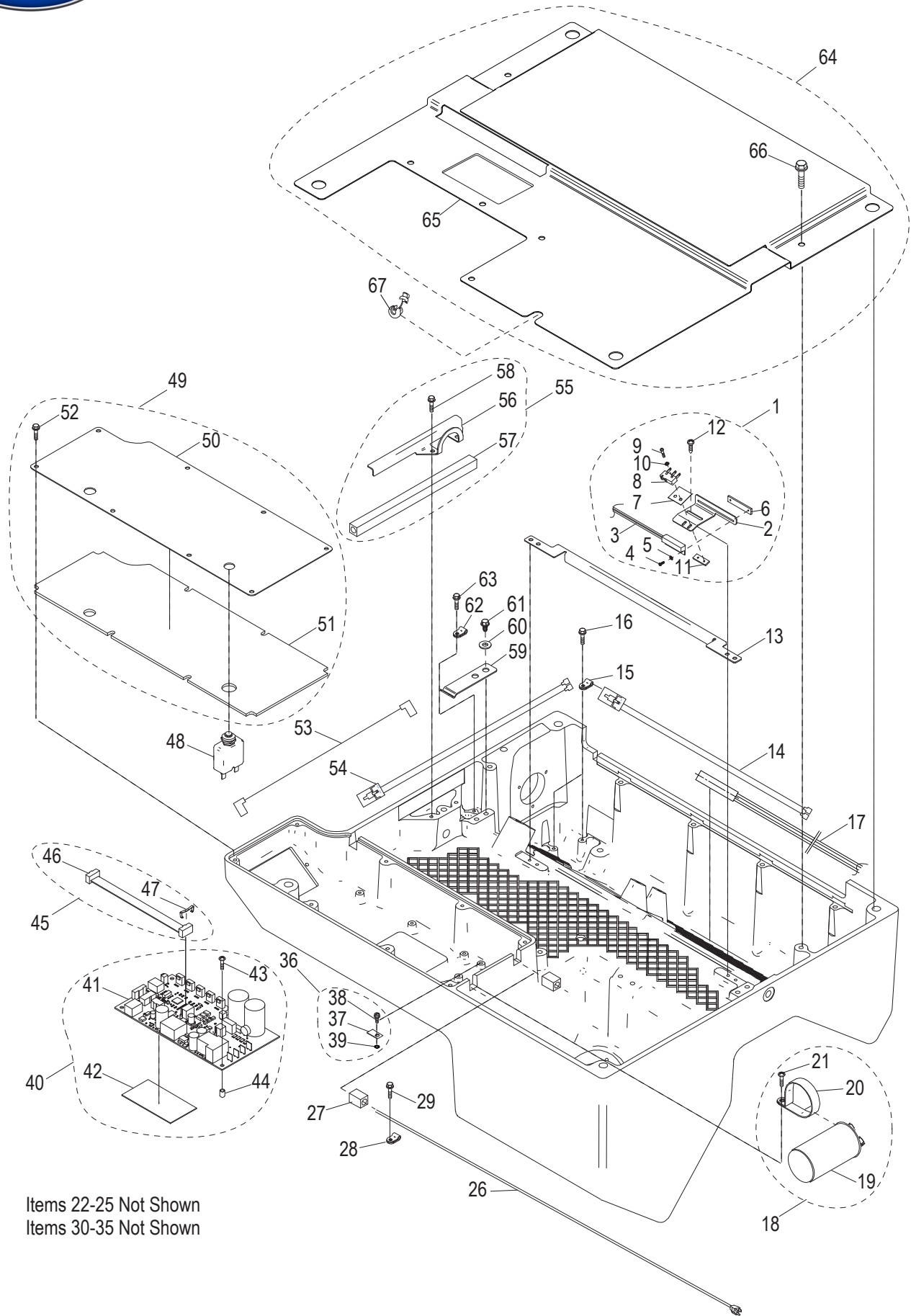

Items 22-25 Not Shown
Items 30-35 Not Shown



S13A-15 Electrical Base Components

Item	Part Number	Description	Qty	Serial Number
1	121084	(Incl. items 2-12)	1	
2		Cut/Auto Engage Sensor Mount	1	
3		Sensor, Reed Switch, Cut Sensor	1	
4		Mach. Screw #1-64x1/4, 18-8 Pan Hd. Phillips (SST)	2	
5		Lock Washer #2 Internal Tooth	2	
6		Nut Plate	1	
7		Micro Switch Insulator	1	
8		Micro Switch, Pin Action	1	
9		Mach. Screw #2-56x7/16 Pan Hd. Phillips	2	
10		Lock Washer #2 Internal Tooth	2	
11		Nut Plate	1	
12	800069	Screw #8-32x3/8 Cross Rec. Pan Hd. Tapping	4	
13	310208	Inner Wireway Cover	1	
14	100122	Wiring Harness, Automatic Switch	1	
15	110226	Clamp, Nylon Loop	2	
16	800069	Screw #8-32x3/8 Cross Rec. Pan Hd. Tapping	2	
17	110107	Harness, Reed Switch, Knife Cover Sensor	1	
18	121082-01	Capacitor Clamp Kit (Incl. items 19-21)	1	
19		Capacitor, Knife Motor (120V)	1	
20	110228	Capacitor Clamp	1	
21	800069	Screw #8-32x3/8 Cross Rec. Pan Hd. Tapping	1	
22	121082-02	Capacitor Clamp Kit (Incl. items 23-25) Not Shown	1	
23		Capacitor, Knife Motor (220V) Not Shown	1	
24	110229	Capacitor Clamp Not Shown	1	
25	800069	Screw #8-32x3/8 Cross Rec. Pan Hd. Tapping Not Shown	1	
26	130225	Power Supply Cord, 120VAC, 15A	1	
27	510045-01	Sleeve, Large Diameter Wire	2	
27	110227	Strain Relief, Power Cord	1	
28	800057	Screw 1/4-20x.75 Hex Washer Hd Tapping	1	
30	130008-01	Power Cord (220V) Not Shown	1	
31		Power Supply Cord Not Shown	1	
32		Male Power Plug, Europe CEE7/7, 50Hz Not Shown	1	
33	130008-02	Power Cord (220V) Not Shown	1	
34		Power Supply Cord Not Shown	1	
35		Three Blade Male Plug, NEMA 3-15, 60Hz Not Shown	1	
36	121080	Ground Location Tab Kit (Incl. items 37-39)	1	
37		Ground Location Tab	1	
38		Screw, Green #8-32x5/16" SL Hex Washer Hd	1	
39		Lock Washer #8 External Tooth	1	
40	121088-01	Control Board Kit (Incl. items 41-44)	1	
41		Control Board Assembly	1	
42	510050	Thermal Pad	1	
43	800175	Screw #8-32x3/4 Crossed Recessed Tapping	4	
44	810450	Self Retaining Spacer	4	
45	121081	Ribbon Cable Kit (Incl. items 46-47)	1	
46		Ribbon Cable Assembly	1	
47		Retaining Clip, Ribbon Cable	2	
48	140017-01	Circuit Breaker (120V)	1	
48	140017-02	Circuit Breaker (220V) Not Shown	1	
49	300063	Electronics Cover & Gasket Kit (Incl. items 50-52)	1	
50		Cover, Electronics	1	
51		Gasket, Electronic Cover	1	
52	810349	Tapping Screw 10 x 1/2 PH, Torx	8	



S13A-15 Electrical Base Components

Item	Part Number	Description	Qty	Serial Number
53	100125	Wire Harness, Circuit Breaker	1	
54	100120	Wiring Harness, Carriage Tilt Sensor	1	
55	300067	Front Wireway Cover Kit (Incl. items 56-58)	1	
56		Cover, Front Wireway	1	
57	510045-02	Sleeve, Large Diameter Wire	1	
58	800067	Screw #10-24x1/2 Hex Washer Hd Tapping	2	
59	300019	Auto Engage Position Leaf Spring	1	
60		Washer 1/4 Flat	4	
61	800057	Screw 1/4-20x.75 Hex Washer Hd Tapping	2	
62	110230	Nylon Loop Clamp 5/16	1	
63	800069	Screw #8-32x3/8 Cross Rec. Pan Hd. Tapping	1	
64	300068-02	Bottom Cover Assembly (Incl. items 65-66)	1	
65	300139	Bottom Cover	1	
66	810464	Machine Screw 1/4-20 x 1 1/4	2	
67	877	Strain Relief, Power Cord	1	
-	29		0	



INTENTIONALLY LEFT BLANK PAGE



S13A-15 Knife Drive Motor Components

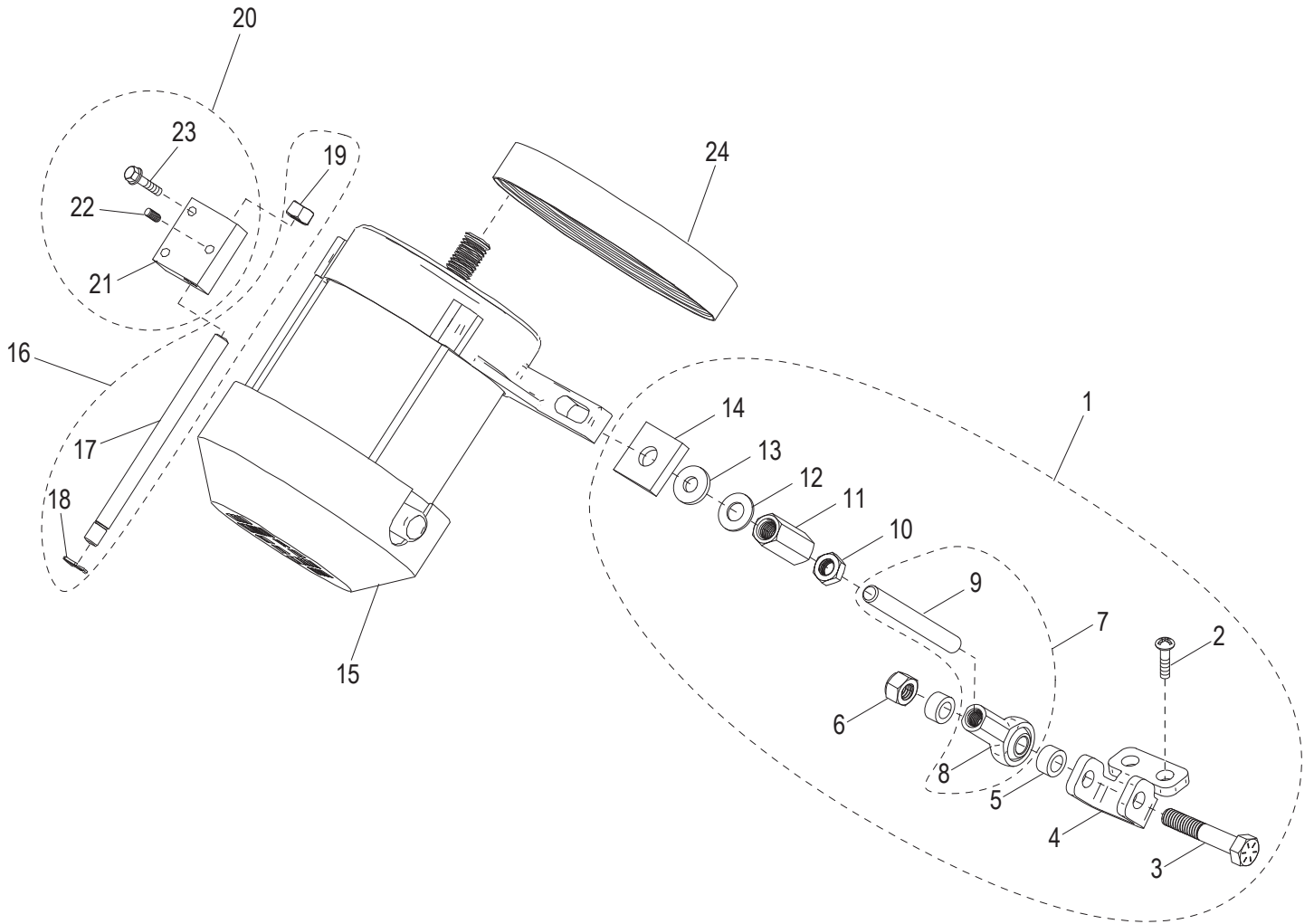



S13A-15 Knife Drive Motor Components

Item	Part Number	Description	Qty	Serial Number
1	400124	Knife Tensioner Kit (Incl. items 2-14)	1	
2	800135	Thread Forming Screw 1/4-20x5/8 PHP	2	
3		Cap Screw 5/16-18 x 1-3/4, Grade 8 Hex Hd	1	
4		Knife Motor Tensioner Bracket	1	
5		Sleeve Spacer	2	
6	810420	Nyloc Nut 5/16-18, Grade 5	1	
7	400125	Threaded Ball Joint, Knife Tensioner (Incl. items 8-9)	1	
8		Ball Joint Rod End 5/16'-24 Thd	1	
9		Tension Shaft 5/16-24 x 3 Full Thread	1	
10		Nut 5/16-24 UNF Zinc Plated Steel Hex Jam	1	
11		Nut 5/16-24x1 Hex Coupling	1	
12	810416	Flat Washer 5/16 (Zinc)	1	
13	810417	Washer 5/16 Neoprene	1	
14	800161	Washer 5/16 Leveling	1	
15	120158-01	Knife Drive Motor, Single Phase, 120V, 60Hz	1	
15	120158-02	Knife Drive Motor, Single Phase, 220V, 60Hz Not Shown	1	
15	120158-03	Knife Drive Motor, Single Phase, 220V, 50Hz Not Shown	1	
16	400113	Motor Mount Pivot Rod Assembly (Incl. items 17-19)	1	
17		Motor Mount Pivot Rod	1	
18	810429	Retaining Ring, 5304-31 (Klipring)	1	
19	810420	Nyloc Nut 5/16-18, Grade 5	1	
20	400123	Motor Pivot Block Kit (Incl. items 21-23)	1	
21		Motor Pivot Block	1	
22	800094	Set Screw #10-32x1/4, Knurl-Grip Cup Pt.	1	
23	800068	Washer #10-24x1 Hex Hd Tap. Screw Slotted	2	
24	800092	Knife Drive Belt	1	



S13A-15 Transport Arm Assembly Components

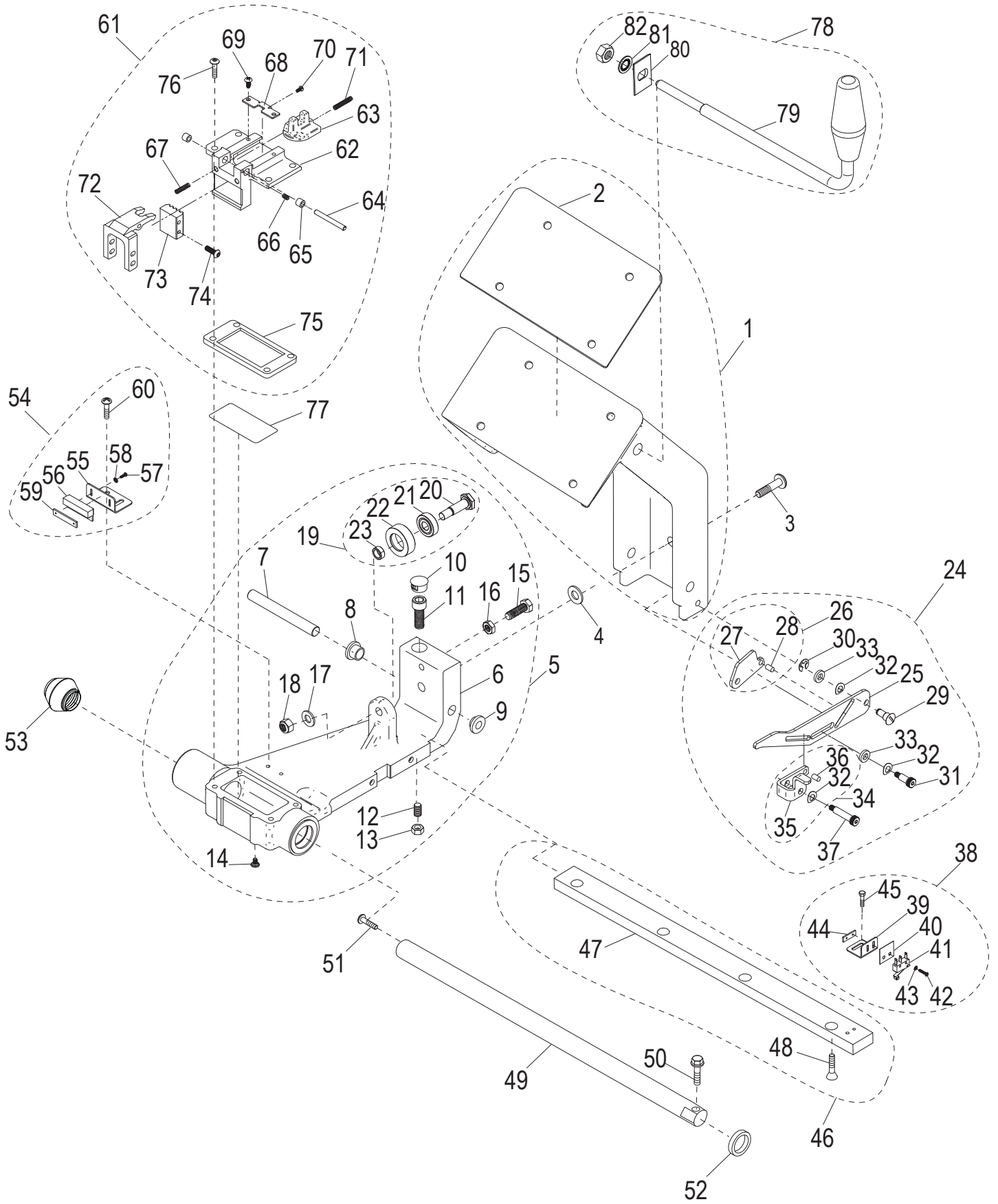



S13A-15 Transport Arm Assembly Components

Item	Part Number	Description	Qty	Serial Number
1	400129	Carriage Arm & Gasket Kit	1	
2	500004	Carriage Arm Gasket	1	
3	820027	Modified Mach. Screw 3/8-16x1-1/2, Button Hd Torx	1	
4	800149	Captive Knob Retainer	1	
5	400115	Transport Replacement Assembly (Incl. items 6-23)	1	
6		Transport with Bushings	1	
7	400017	Transport Attachment Pin	1	
8		Shoulder Washer .51 IDx.88 Nylon	1	
9		Shoulder Washer .51 IDx1.125 Nylon	1	
10		Dome Plug for 5/8 Hole	1	
11		Socket Hd Cap Screw 3/8-16 x 1 (SST)	1	
12	800015	Transport Tie Down Screw	1	
13	800048	Nut 5/16-24 Hex UNF Thread (Zinc Plated Steel)	1	
14		Mach. Sealing Screw 8-32x1/4 PH Phillips	1	
15	810406	Hex Cap Screw 5/16-24x1,18-8 (SST)	1	
16		Shoulder Washer .51 IDx1.125 Nylon	1	
17	810272	Flat Washer 5/16 Screw Size (SST)	1	
18	810420	Nyloc Nut 5/16-18, Grade 5	1	
19	800014	Roller Bearing Assembly (Incl. items 20-23)	1	
20		Roller Bearing Bolt	1	
21		Roller Bearing	1	
22		Bearing Sleeve	1	
23		Spacer Sleeve	1	
24	300069	Transport Interlock Kit (Incl. items 25-37)	1	
25		Transport Slide Lock Plate	1	
26		Lock Plate Assembly (Incl. items 27-28)	1	
27		Lock Plate	1	
28		Dowel Pin, 5/32 x 5/16 (SST)	1	
29		Reverse Shoulder Bolt	1	
30		E-Clip Retaining Ring for 1/4" Shaft	1	
31		Shoulder Bolt 1/4" x 1/2", #10-32 Thread	1	
32		Curved Disk Spring .265 ID,.490 OD,.011 Thick	3	
33		Washer, Nylon .265 ID, .50 OD, .094 Thick	2	
34		Cam Lock Plate Assembly (Incl. items 35-36)	1	
35		Cam Lock Plate	1	
36		Dowel Pin, 5/32 x 5/16 (SST)	1	
37		Shoulder Bolt 1/4" x 1", #10-32 Thread	1	
38	121089	Carriage Tilt Switch Kit (Incl. items 39-45)	1	
39		Carriage Tilt Back Sensor Mount	1	
40		Micro Switch Insulator	1	
41		Micro Switch	1	
42		Mach. Screw #2-56x7/16 Pan Hd. Phillips	2	
43		Lock Washer #2 Internal Tooth	2	
44		Nut Plate	1	
45	800099	Mach. Screw #8-32x3/8 Hex Hd	2	
46	400131	Transport Roller Bar Kit (Incl. items 47-48)	1	
47		Transport Roller Bar	1	
48	810004	Tapping Screw 1/4-20x1 Cross Rec. FH	4	
49		Transport Shaft	1	
50	800059	Washer 5/16-18x1.25 Hex Hd Tapping Screw	1	
51	810378	Mach. Screw 5/16-18x1 Button Hd	1	
52	500005	Transport Bumper	1	
53	800131	Sleeved Spring Assembly	1	



S13A-15 Transport Arm Assembly Components

Item	Part Number	Description	Qty	Serial Number
54	121090	Carriage Magnet Kit (Incl. items 55-60)	1	
55		Transport Switch Magnet Mount	1	
56		Magnet	1	
57		Mach. Screw #1-64x1/4, 18-8 Pan Hd. Phillips (SST)	2	
58		Lock Washer #2 Internal Tooth	2	
59		Nut Plate	1	
60	800069	Screw #8-32x3/8 Cross Rec. Pan Hd. Tapping	2	
61	400130	Auto Engage Pickup Kit (Incl. items 62-76)	1	
62		Transport Auto Engage	1	
63		Auto Engage Slide	1	
64		Auto Engage Pivot Dowel	1	
65		Sleeve Bushing	1	
66	810473	Set Screw, 8-32x3/8, Brass Tip Dog Point (SST)	1	
67		Clamp Release Spring	1	
68		Auto Engage Spring Stop Bracket	1	
69	800069	Screw #8-32x3/8 Cross Rec. Pan Hd. Tapping	1	
70	810423	Mach. Screw #4-40 x 1/4, 18-8 PH Cr (SST)	1	
71		Slide Spring	1	
72		Auto Engage Pivot Lever	1	
73	800105	Socket Cap Screw #10-32x5/8 Button-Hd	1	
74		Auto Engage Belt Clamp	1	
75	510058	Oil Well Gasket	1	
76	800109	Screw 1/4-20x.50 Button Hd Cap	4	
77	800053	Felt Insert	1	
78	400114	Carriage Arm Handle Assembly with Nut (Incl. items 79-82)	1	
79		Carriage Arm Handle	1	
80	400155	Anti Rotation Block	1	
81	810226	Lock Washer, 1/2 Screw Size, Internal Tooth	1	
82	810224	Hex Nut, 1/2-13 Left Hand, Thread	1	



INTENTIONALLY LEFT BLANK PAGE



S13A-15 Automatic Drive Assembly Components

Item 1
Automatic Drive Kit

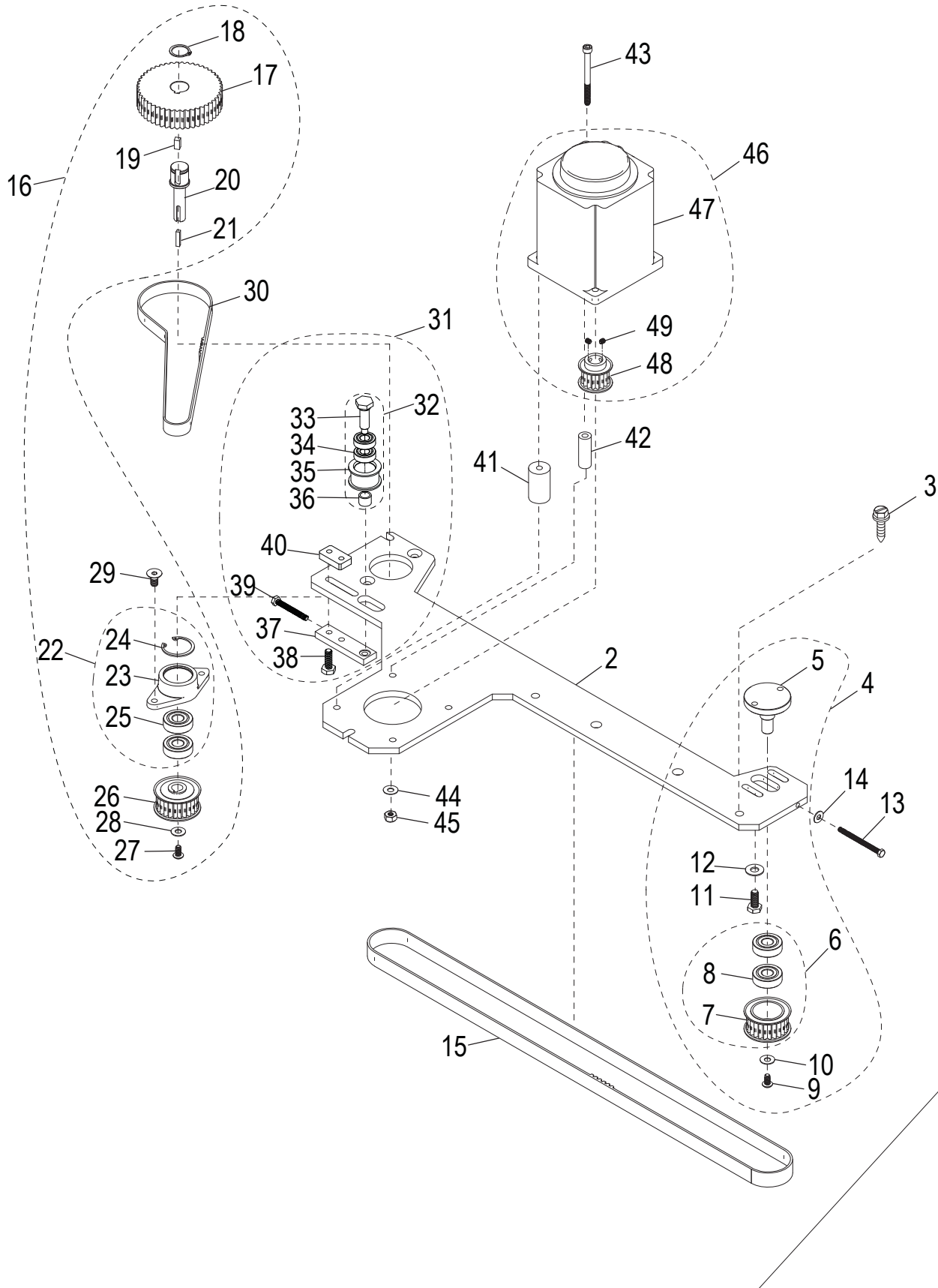



S13A-15 Automatic Drive Assembly Components

Item	Part Number	Description	Qty	Serial Number
1	400133	Automatic Drive Kit (Incl. items 2-49)	1	
2		Automatic Base Plate	1	
3	800057	Screw 1/4-20x.75 Hex Washer Hd Tapping	4	
4	400143	Idler Assembly Kit (Incl. items 5-12)	1	
5		Pulley Shaft	1	
6	450097	Idler Assembly (Incl. items 7-8)	1	
7		Idler Pulley (24 Tooth)	1	
8		Bearing 6000 Double Seal	2	
9	800077	Mach. Screw #10-24x3/8 Button Hd Cap (SST)	1	
10	800076	Washer #10 Flat (18-8 SST)	1	
11	800072	Bolt 1/4-20x5/8' Hex	2	
12		Washer 1/4 Flat	2	
13	800088	Mach. Screw #8-32x2 Hex Hd (SS)	1	
14	870072	#8 Flat Washer, SST	1	
15	800008	Automatic Driven Belt	1	
16	400141	48/24 Tooth Drive Pulley Kit (Incl. items 17-29)	1	
17		Drive Pulley (48 Tooth)	1	
18		Retaining Ring 5100-62 External	1	
19		Key, 3/16x3/16 Drive	1	
20		Shaft, Dual Pulley	1	
21		Key, 1/8x1/8 Drive	1	
22	450096	Bearing Block Assembly (Incl. items 23-25)	1	
23		Bearing Block	1	
24		Retaining Ring N5002-102 Internal	1	
25		Bearing 6000 Double Seal	2	
26	450093	Drive Pulley (24 Tooth)	1	
27	800077	Mach. Screw #10-24x3/8 Button Hd Cap (SST)	1	
28	800076	Washer #10 Flat (18-8 SST)	1	
29		Screw 1/4-20x1/2 Socket Flat Countersunk Hd Cap	2	
30	800009	Automatic Drive Belt	1	
31	400154	Belt Tension Kit (Incl. items 32-40)	1	
32	400151	Belt Tensioner Assembly	1	
33		Tension Pulley Shaft	1	
34		Bearing, Tension	2	
35		Tension Sleeve	1	
36		Spacer	1	
37		Tensioner Bar	1	
38	810431	Cap Screw 1/4-20 x 3/4 Hex Hd	2	
39	810007	Screw, Machine #10-32x1-1/2 Hx Hd Drive	1	
40	400150	Nut Plate	1	
41	450090	Standoff, Automatic Motor	3	
42	450091	Standoff, Automatic Motor	1	
43	800074	Screw #10-24x2.25 Socket Hd Cap	4	
44	800076	Washer #10 Flat (18-8 SST)	4	
45	800075	Nut #10-24 Hex	4	
46	400144	Carriage Drive Motor Kit (Incl. items 46-49)	1	
47	120160	Carriage Drive Motor (BLDC)	1	
48		Motor Drive Pulley (16 Tooth)	1	
49	800091	Set Screw #8-32 x 3/16 Knurled Grip - Cup Pt.	2	



S13A-15 Automatic Lift Lever Base Components

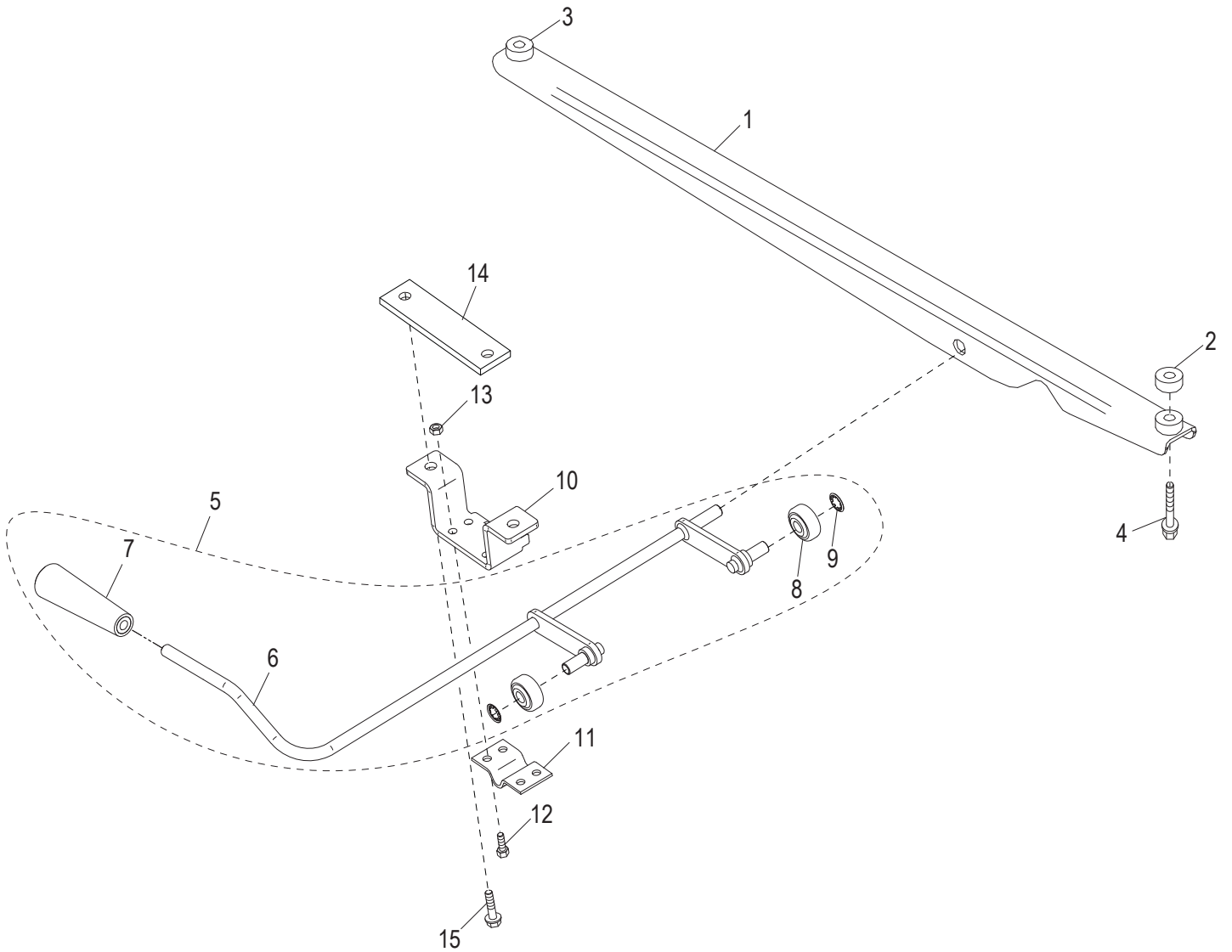



S13A-15 Automatic Lift Lever Base Components

Item	Part Number	Description	Qty	Serial Number
1		Lift Lever Base Support	1	
2	400160	Lift Lever Base Support Spacer	2	
3	400037	Lift Lever Base Support Post	2	
4	810464	Machine Screw 1/4-20 x 1 1/4	2	
5	400163	Lift Lever Assembly Kit (Incls. items 6-9)	1	
6		Lift Lever Weldment	1	
7		Lift Lever Handle	1	
8		Lift Lever Roller	2	
9		Retaining Ring 5115-37 Push-On External	2	
10	300078	Lift Lever Support & Stop	2	
11	300030	Lift Lever Bracket	1	
12	810373	Mach. Screw 1/4-20x5/8 Button Hd	2	
13	810438	Nylon-Insert Nut 1/4-20 Grade 5 Stl Zinc Plated	1	
14	400159	Lift Lever Spacer Plate	1	
15	800058	Washer 5/16-18-1 Hex Hd Tapping Screw	2	



S13A-15 Carriage and End Weight Assembly Components

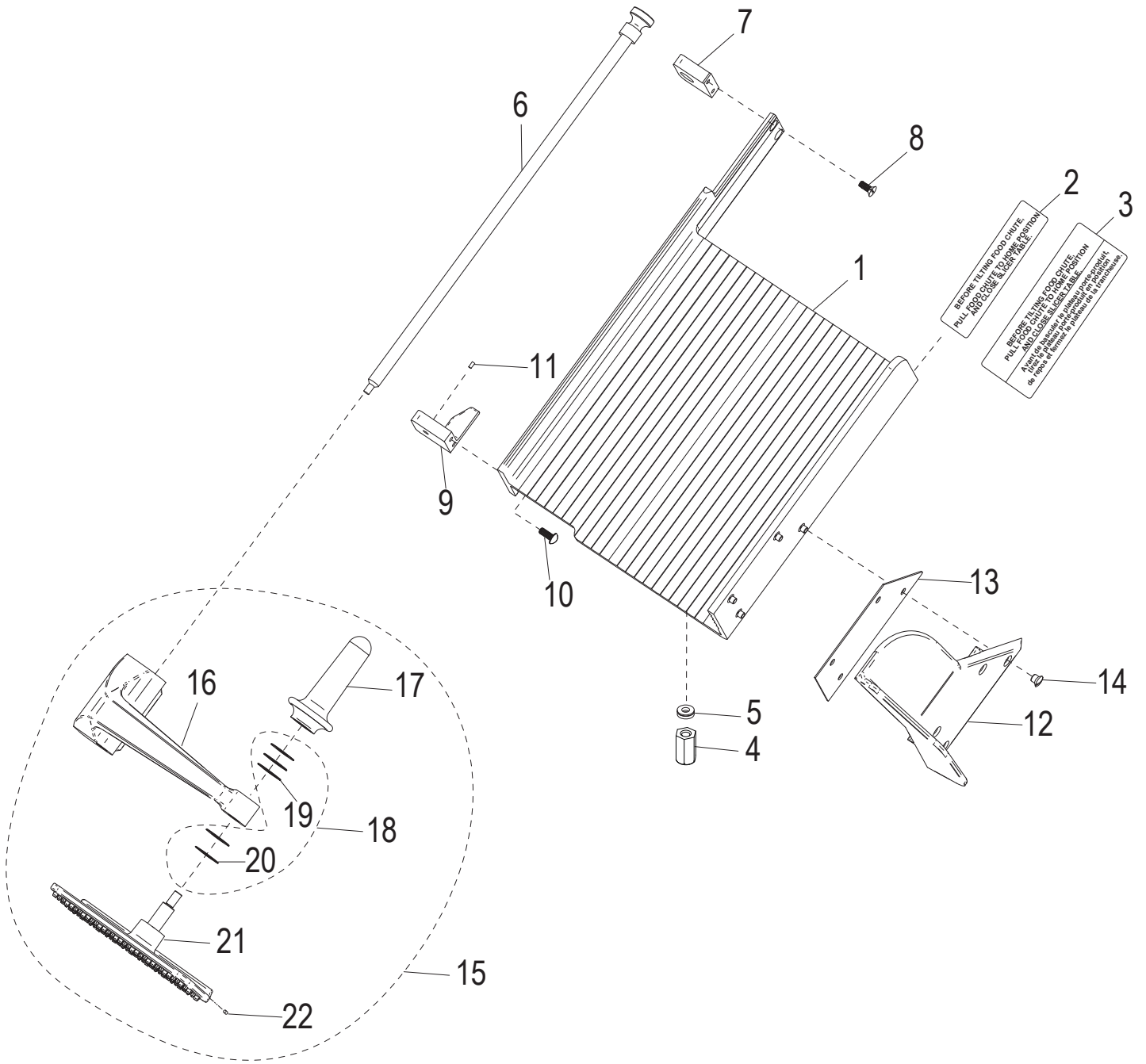



S13A-15 Carriage and End Weight Assembly Components

Item	Part Number	Description	Qty	Serial Number
1	400012	Carriage Insert Assembly	1	
2	920196	Carriage Tilt Label	1	
3	920197	Carriage Tilt Label (French)	1	
4	800188	Custom Nut, 1/4-20	4	
5	800085	Washer 1/4" Screw, Self Aligning	4	
6	450197	End Weight Shaft Assembly	1	
7		End Weight Rod Mount	1	
8	810372	Mach. Screw 1/4-20x3/4 Flat Hd	2	
9		End Weight Stop	1	
10	810373	Mach. Screw 1/4-20x5/8 Button Hd	2	
11	800205	Stop Pin, Delrin End Weight	1	
12		Carriage Thumb Guard	1	
13	510038	Carriage Thumb Guard Gasket	1	
14	430054	Thumb Guard Screw, Tamper Proof	4	
15	500027	End Weight Assembly (Incl. items 16-22)	1	
16	420065	End Weight Arm Assembly	1	
17	500024	End Weight Handle	1	
18	800164	End Weight Face Washer Kit (Incl. items 19-20)	1	
19		Washer .04 mm thick End Weight Face	1	
20		Washer .01 mm thick End Weight Face	4	
21	500007	Molded End Weight Assembly	1	
22	800047	Delrin 1/8 Dia x 3/8 Pin	1	



S13A-15 Knife and Knife Cover Components

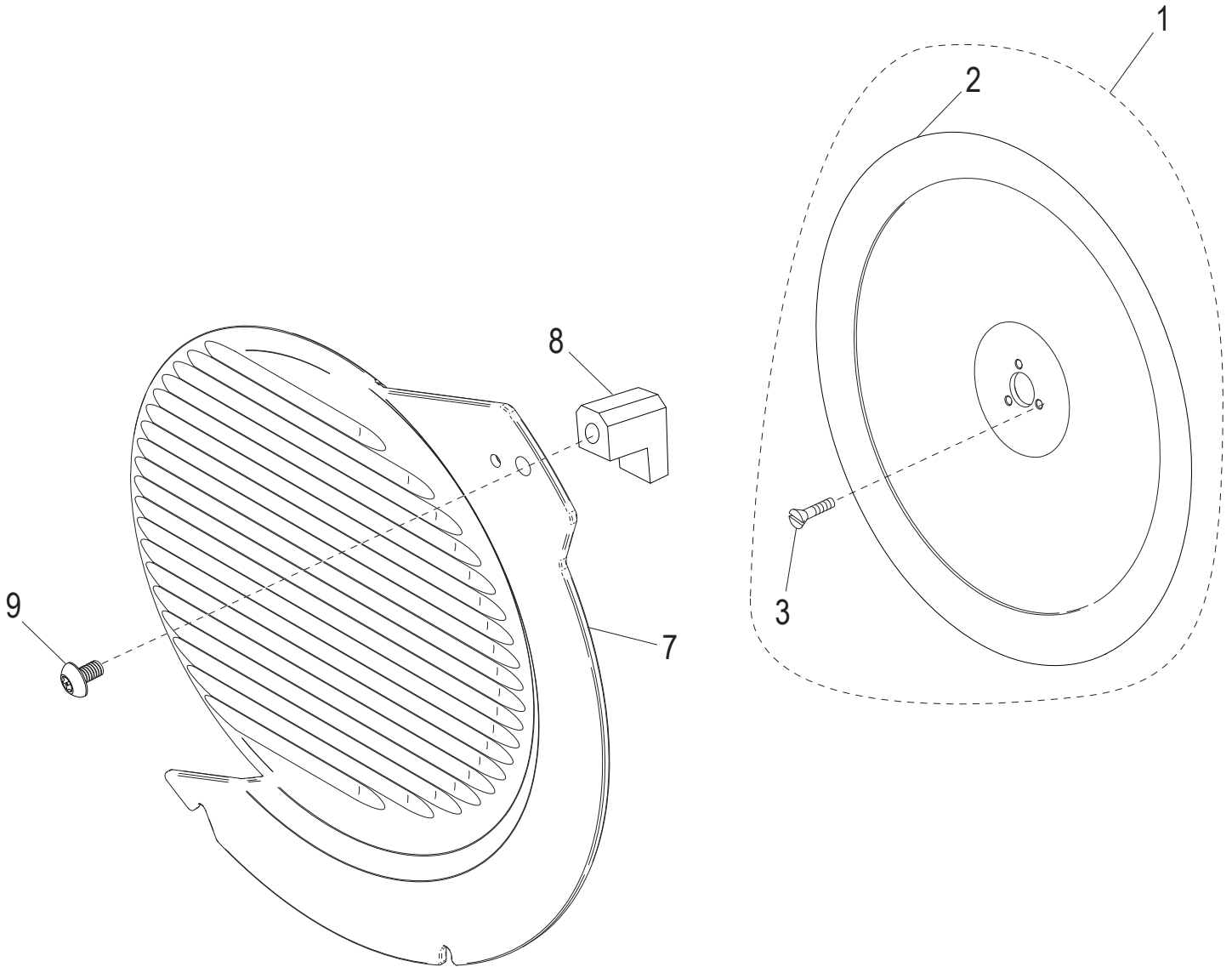

Items 4-6 Not Shown



S13A-15 Knife and Knife Cover Components

Item	Part Number	Description	Qty	Serial Number
1	400139	Knife Kit (Incl. items 2-3)	1	
2		Knife, 13 Inch Steel	1	
3	810274	Mach. Screw, Flat Hd Slotted 10-32x1/2 (SST)	3	
4	400161	Stainless Steel Knife Kit (Incl. items 5-6) Not Shown	1	
5		Knife, 13 inch (SST) Not Shown	1	
6	810274	Mach. Screw, Flat Hd Slotted 10-32x1/2 (SST) Not Shown	3	
7	250063	Knife Cover	1	
8	430056	Knife Cover Lock	1	
9	810377	Mach. Screw 5/16-18x3/4 Button Hd Torx	1	



S13A-15 Dummy Sharpener Assembly

Item 1
Dummy Sharpener Assembly

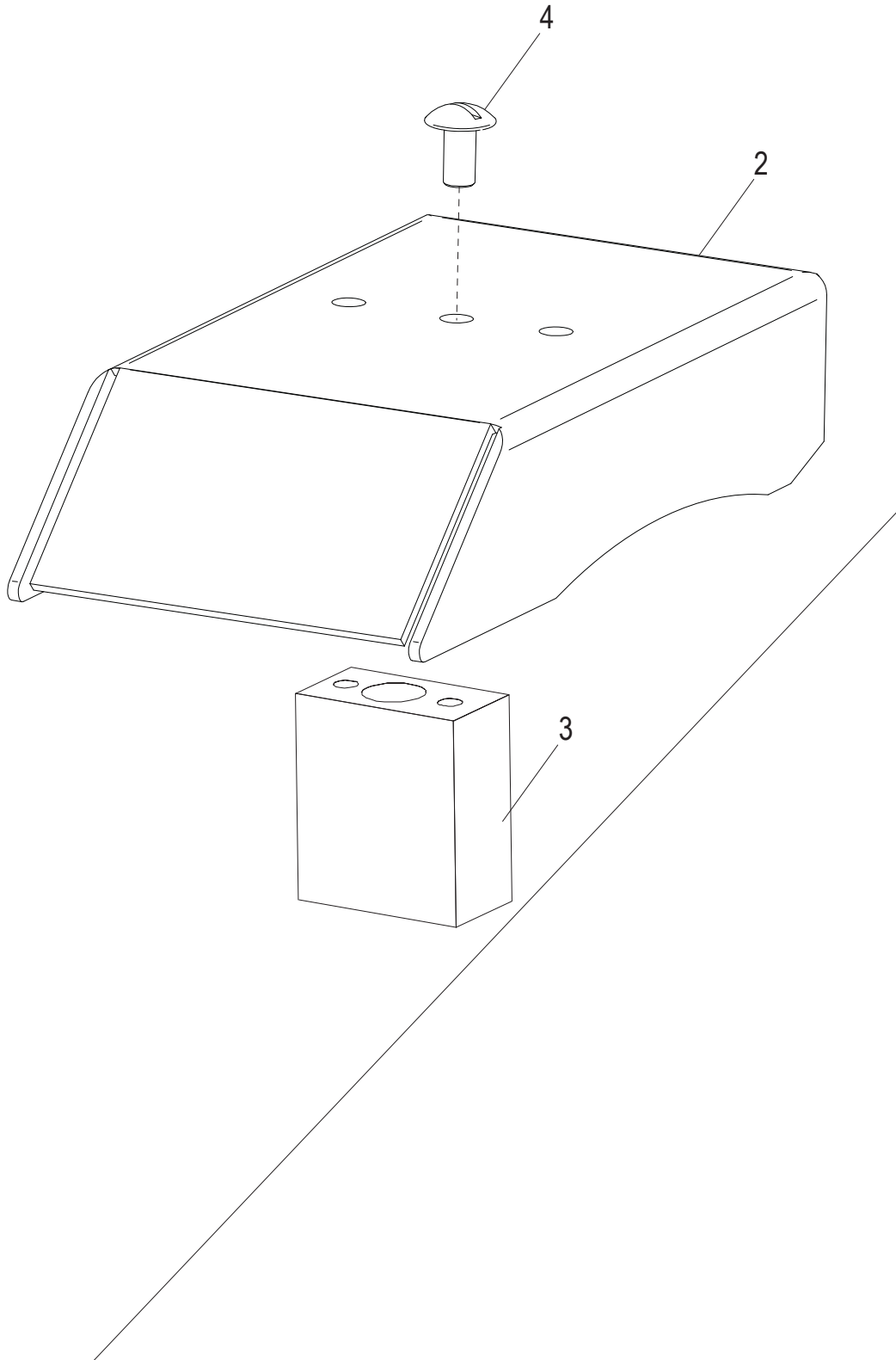



S13A-15 Dummy Sharpener Assembly

Item	Part Number	Description	Qty	Serial Number
1	310255	Dummy Sharpener Assembly	1	
2		Dummy Sharpener Top	1	
3		Dummy Sharpener Base	1	
4	810180	Mach. Screw, Tamper-Proof, 1/4-20 x .50	3	



S13A-15 Wiring Schematic

- *Carriage Tilt Wire Harness - P/N 100120
- *Carriage Switch Wire Harness - P/N 100122
- *Ribbon Cable - P/N 100126

