

TOP

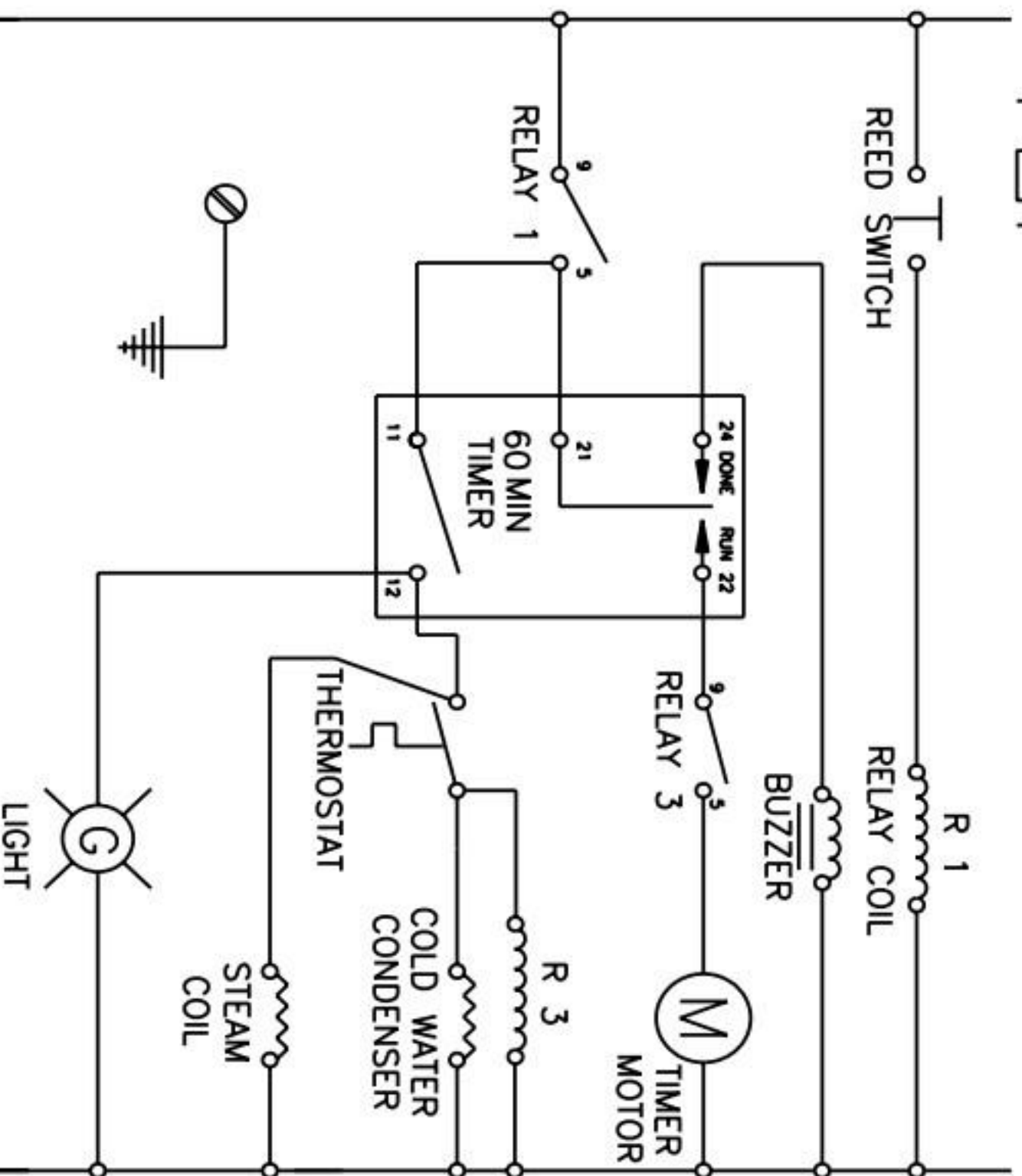

BOTTOM

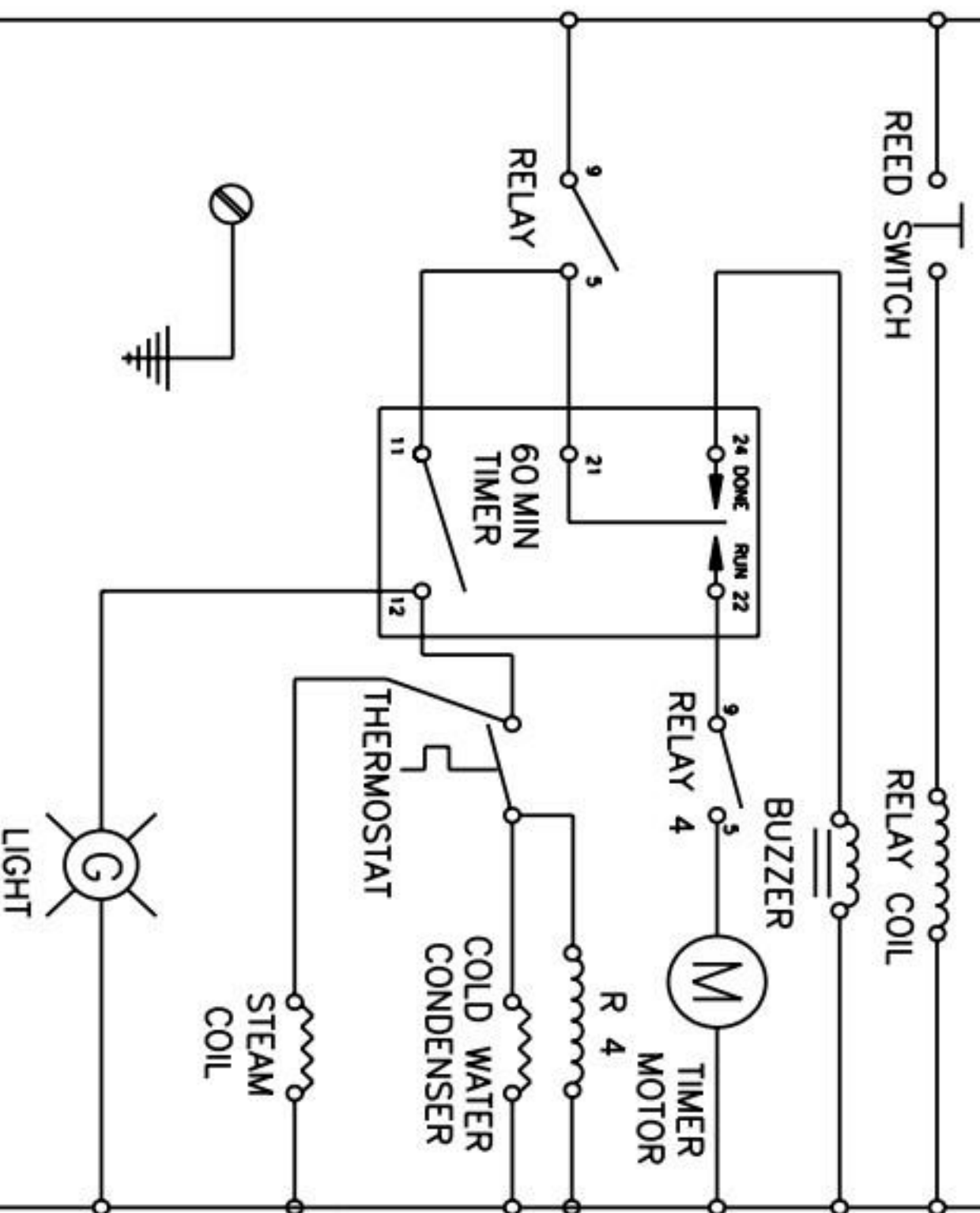

FRONT CONTROL PANEL

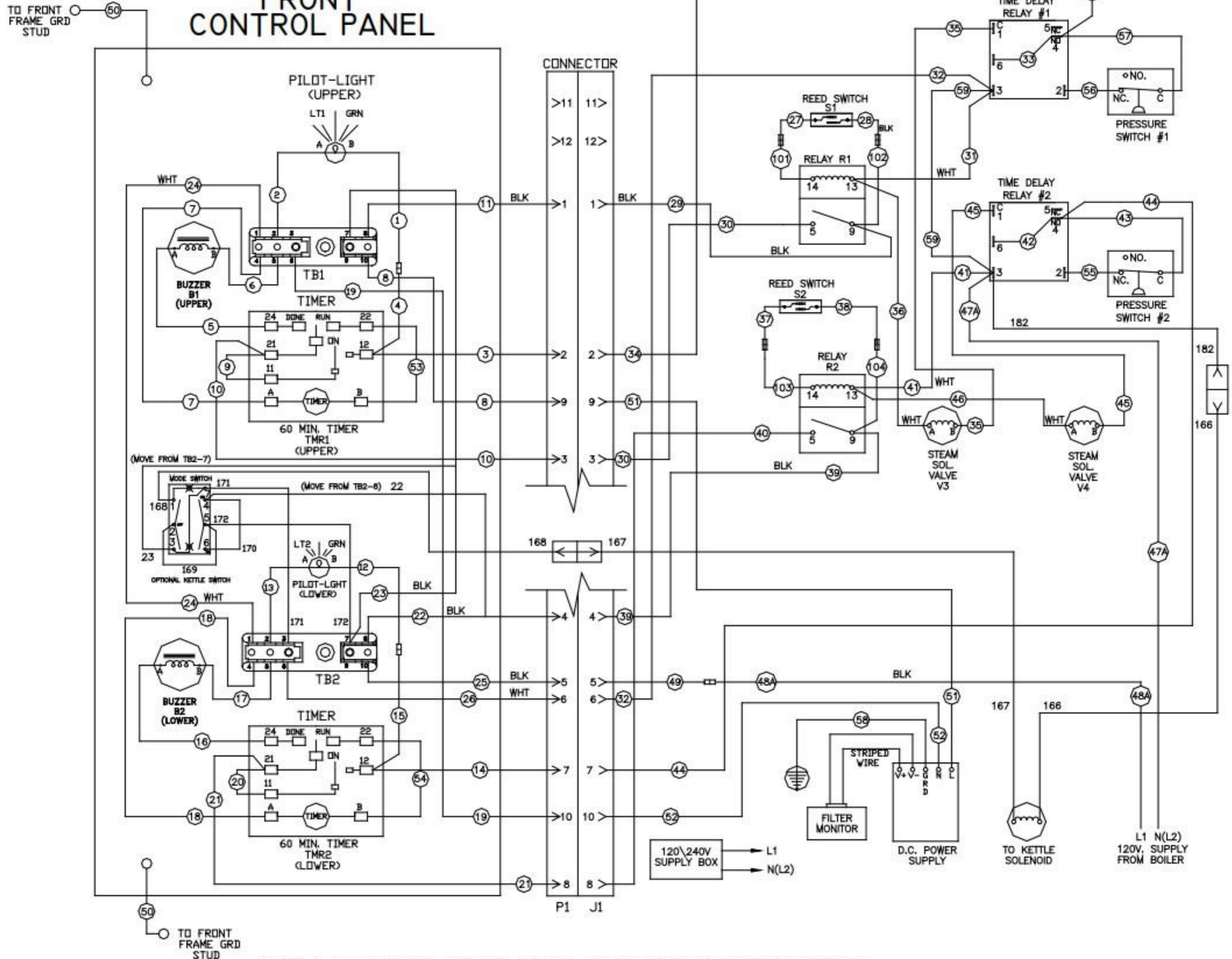

- NOTES: 1. ALL WIRES 18 AWG AND YELLOW EXCEPT WHERE INDICATED OTHERWISE.
 2. FOR WIRE LEAD SCHEDULE REFER TO DRAWING C 98-4376.
 3. HIDDEN LINES REPRESENT OPTIONAL COMPONENTS AND WIRING

