

Select
by **southbend**

IMPORTANT FOR FUTURE REFERENCE

Please complete this information and retain this manual for the life of the equipment:

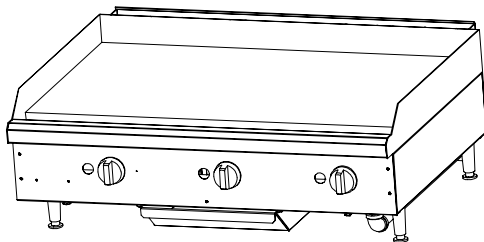
Model #: _____

Serial #: _____

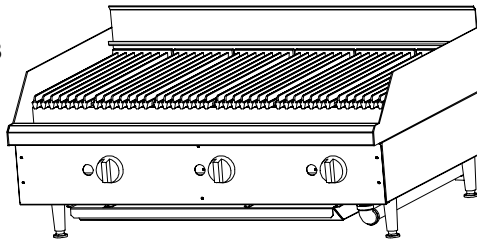
Date Purchased: _____

OPERATOR'S MANUAL

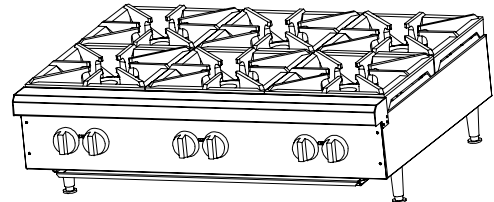
Medium Duty Counterline



Griddle Models MDG-24, MDG-36 (shown), and MDG-48
Thermostatic Griddle Models MDGT-24, MDGT-36, and MDGT-48



Charbroiler Models MDC-24, MDC-36, and MDG-48
Lava-Rock Models MDCL-24, MDCL-36 (shown), and MDCL-48



Open Top Models MDO-12, MDO-24, and MDO-36 (shown)

! WARNING

Improper installation, adjustment, alteration, service or maintenance can cause property damage, injury or death. Read the installation, operating and maintenance instructions thoroughly before installing or servicing this equipment.

1100 Old Honeycutt Road, Fuquay-Varina, NC 27526
(800) 348-2558 or (919) 552-9161 • FAX (800) 348-2558 or (919) 552-9798



SAFETY PRECAUTIONS

Before installing and operating this equipment, be sure everyone involved in its operation is fully trained and aware of precautions. Accidents and problems can be caused by failure to follow fundamental rules and precautions.

The following symbols, found throughout this manual, alert you to potentially dangerous conditions to the operator, service personnel, or to the equipment.



This symbol warns of immediate hazards that will result in severe injury or death.



This symbol refers to a potential hazard or unsafe practice that could result in injury or death.



This symbol refers to a potential hazard or unsafe practice that could result in injury, product damage, or property damage.



This symbol refers to information that needs special attention or must be fully understood, even though not dangerous.

**! WARNING
FIRE HAZARD
FOR YOUR SAFETY**

Do not store or use gasoline or other flammable vapors and liquids in the vicinity of this or any other appliance.

Keep area around appliances free and clear of combustibles.

Purchaser of equipment must post in a prominent location, detailed instructions to be followed in the event the operator smells gas. Obtain the instructions from the local gas supplier.

! WARNING

Asphyxiation can result from improper ventilation. Do not obstruct the flow of combustion and ventilation air to and from your cooking equipment.

NOTICE

Be sure this Operator's Manual and important papers are given to the proper authority to retain for future reference.

Congratulations! You have purchased one of the finest pieces of commercial cooking equipment on the market.

You will find that your new equipment, like all Southbend equipment, has been designed and manufactured to meet the toughest standards in the industry. Each piece of Southbend equipment is carefully engineered and designs are verified through laboratory tests and field installations. With proper care and field maintenance, you will experience years of reliable, trouble-free operation. **For best results, read this manual carefully.**

RETAIN THIS MANUAL FOR FUTURE REFERENCE.

Table of Contents

Specifications.....4

Installation9

Operation12

Cleaning.....14

Adjustments16

Troubleshooting18

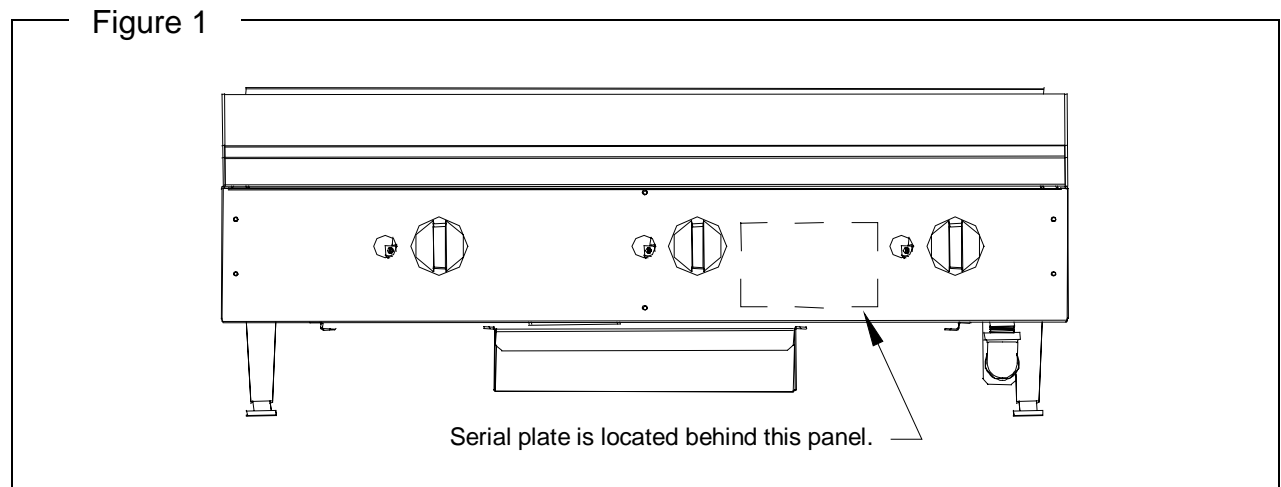
Parts.....21

Read these instructions carefully before attempting installation. Installation and initial startup should be performed by a qualified installer. Unless the installation instructions for this product are followed by a qualified service technician (a person experienced in and knowledgeable with the installation of commercial gas an/or electric cooking equipment) then the terms and conditions on the Manufacturer’s Limited Warranty will be rendered void and no warranty of any kind shall apply.

In the event you have questions concerning the installation, use, care, or service of the product, write to:

Technical Service Department
 Southbend
 1100 Old Honeycutt Road
 Fuquay-Varina, North Carolina 27526 USA

The serial plate is located on the interior side of the valve panel, as shown below:





SPECIFICATIONS

NOTICE

Installation must comply with *National Fuel Gas Code, ANSI Z223.1, Natural Gas Installation Code, CAN/CGA-B149.1*, or the *Propane Installation Code, CAN/CGA-B149.2*, as applicable.

Local codes regarding installation vary greatly from one area to another. The National Fire Protection Association, Inc. states in its NFPA 96 latest edition that local codes are the “authority having jurisdiction” when it comes to installation requirements for equipment. Therefore, installations should comply with all local codes.

Southbend reserves the right to change specifications and product design without notice. Such revisions do not entitle the buyer to corresponding changes, additions, or replacements for previously purchased equipment.

This product is intended for commercial use only, not for household use.

GAS SUPPLY

The Serial Plate is located on the interior side of the valve panel (see Figure 1 on page 3). It indicates the type of gas the unit is equipped to burn. All Southbend equipment is adjusted at the factory. Check type of gas on serial plate.

These models are design-certified for operation on natural or propane gases. The unit is shipped configured for natural gas. A kit for conversion to using propane gas is included (see instructions in kit or page 9 of this manual).

This appliance should be connected **ONLY** to the type of gas for which it is configured.

An adequate gas supply is imperative. Undersized or low pressure lines will restrict the volume of gas required for satisfactory performance. Fluctuations of more than 25% on natural gas or 10% on propane gas will create problems and affect burner operating characteristics. A 1/8" pressure tap is located on the manifold to measure the manifold pressure.

An adequate gas supply line to the unit should be no smaller than the inside diameter of the pipe from the unit to which it is connected.

Purge the supply line to clean out dust, dirt, or other foreign matter before connecting the line to the unit.

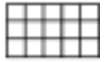
All pipe joints and connections must be tested thoroughly for gas leaks. Use only soapy water for testing on all gases. **NEVER** use an open flame to check for gas leaks. All connections must be checked for leaks after the unit has been put into operation. Test pressure should not exceed 14" W.C.



CAUTION

THIS APPLIANCE AND ITS INDIVIDUAL SHUTOFF VALVE MUST BE DISCONNECTED FROM THE GAS SUPPLY PIPING SYSTEM DURING ANY PRESSURE TESTING OF THAT SYSTEM AT TEST PRESSURES IN EXCESS OF 1/2 PSIG (3.45 kPa).

THIS APPLIANCE MUST BE ISOLATED FROM THE GAS SUPPLY PIPING SYSTEM BY CLOSING ITS INDIVIDUAL MANUAL SHUTOFF VALVE DURING ANY PRESSURE TESTING OF THE GAS SUPPLY PIPING SYSTEM AT TEST PRESSURES EQUAL TO OR LESS THAN 1/2 PSIG (3.45 kPa).



CLEARANCES

! WARNING

There must be adequate clearance between units and adjacent construction. Clearance must also be provided for servicing and for operation.

Minimum Clearances from COMBUSTABLE construction:

	Griddle Models		Open Top Models
Sides	4"		4"
Back	4"		4"
Bottom	4"		4"

Minimum Clearances from NON-COMBUSTABLE construction:

	Griddle Models	Charbroiler Models	Open Top Models
Sides	0"	0"	0"
Back	0"	0"	0"
Bottom	4"	4"	4"

VENTILATION

! WARNING

Improper ventilation can result in personal injury or death. Ventilation which fails to properly remove flue products can cause headaches, drowsiness, nausea, or could result in death.

All units must be installed in such a manner that the flow of combustion and ventilation air are not obstructed. Provisions for adequate air supply must be provided. Do not obstruct the front of the unit at the top by the control panel as combustion air enters through these areas.

NOTICE

Proper ventilation is the owner's responsibility. Any problem due to improper ventilation will not be covered by the warranty.

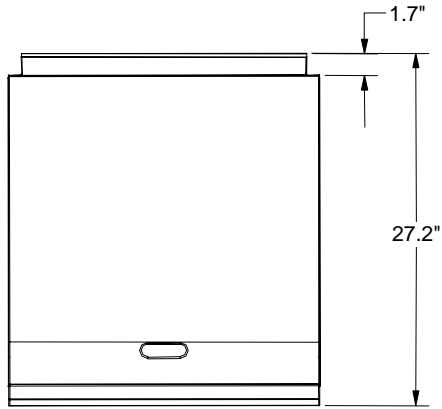
All units must be installed in such a manner that the flow of combustion and ventilation air are not obstructed. Provisions for an adequate air supply must be provided. Do not obstruct the front or rear of the unit, as combustion air enters through this area. Be sure to inspect and clean the ventilation system according to the ventilation equipment manufacturer's instructions.

In case of unsatisfactory performance on any appliance, check the appliance with the hood exhaust fan in the "OFF" position. Do this only long enough to check equipment performance. Then turn the fan back on and let it run to remove any exhaust that may have accumulated during the test.

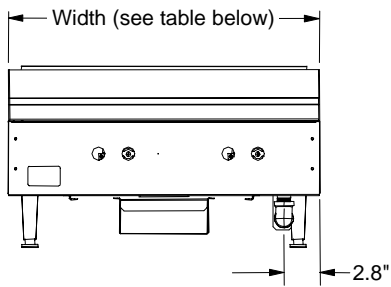
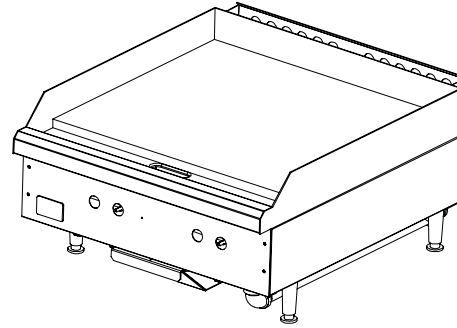


Figure 2

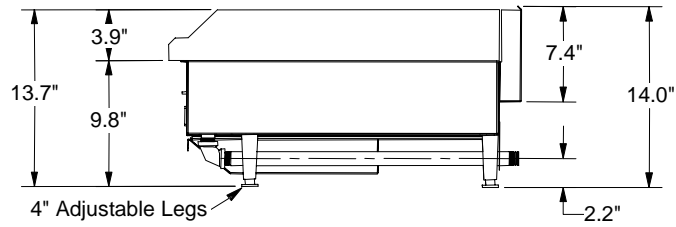
DIMENSIONS OF GRIDDLE & THERMOSTATIC-GRIDDLE MODELS



TOP VIEW



FRONT VIEW



SIDE VIEW

Model	Width	Number and Size of Burners	Total BTU
MDG-24 & MDGT-24	24"	2 @ 20,000	40,000
MDG-36 & MDGT-36	36"	3 @ 20,000	60,000
MDG-48 & MDGT-48	48"	4 @ 20,000	80,000

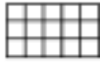
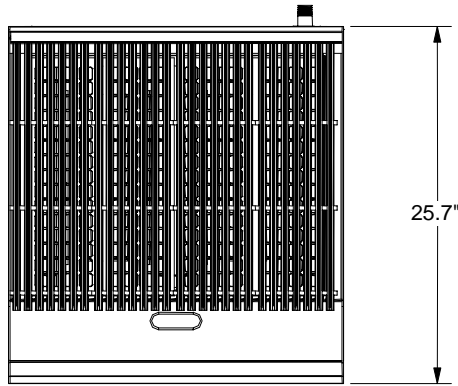
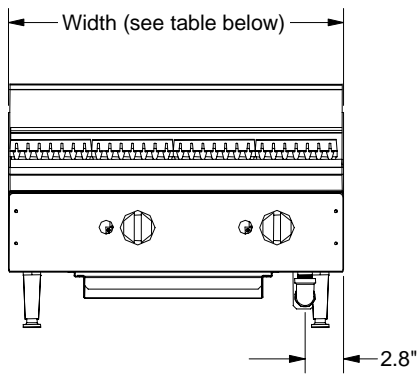
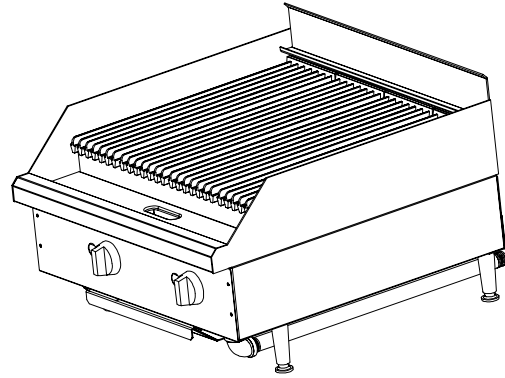


Figure 3

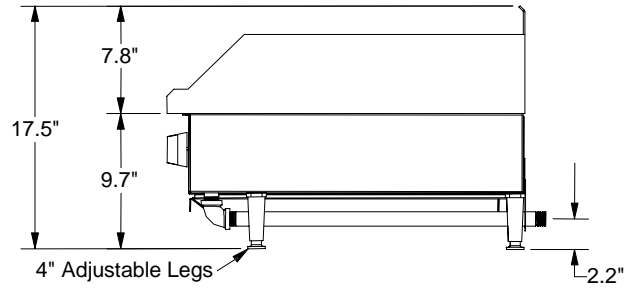
DIMENSIONS OF CHARBROILER MODELS



TOP VIEW



FRONT VIEW



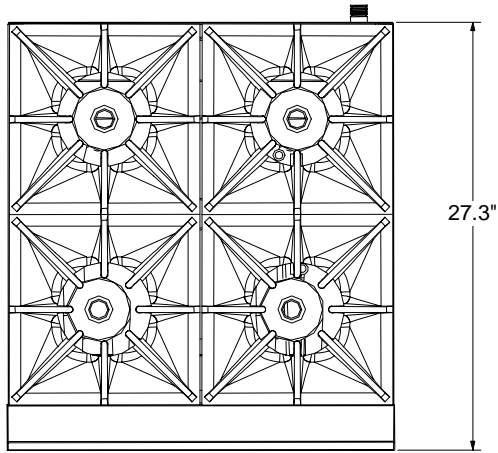
SIDE VIEW

Model	Width	Number and Size of Burners	Total BTU
MDC-24 & MDCL-24	24"	2 @ 20,000	40,000
MDC-36 & MDCL-36	36"	3 @ 20,000	60,000
MDC-48 & MDCL-48	48"	4 @ 20,000	80,000

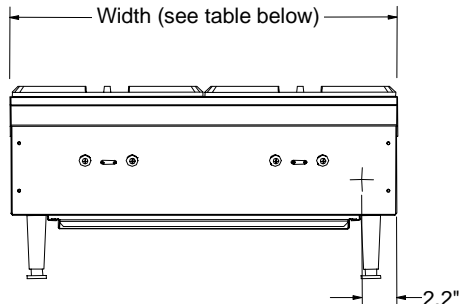
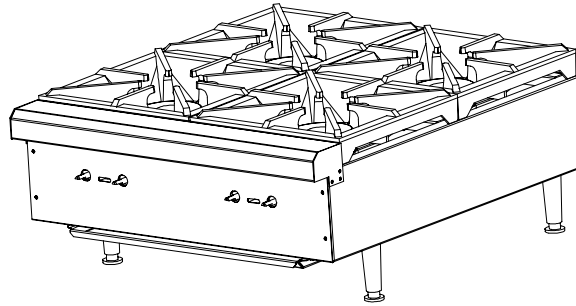


Figure 4

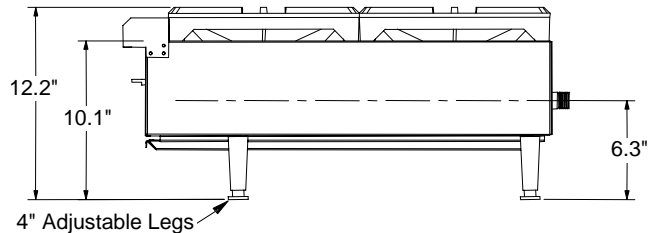
DIMENSIONS OF OPEN TOP MODELS



TOP VIEW



FRONT VIEW



SIDE VIEW

Model	Width	Number and Size of Burners	Total BTU
MDO-12	12"	2 @ 20,000	40,000
MDO-24	24"	4 @ 20,000	80,000
MDO-36	36"	6 @ 20,000	120,000



INSTALLATION

NOTICE

Installation must comply with *National Fuel Gas Code, ANSI Z223.1, Natural Gas Installation Code, CAN/CGA-B149.1*, or the *Propane Installation Code, CAN/CGA-B149.2*, as applicable.

These installation procedures must be followed by qualified personnel or warranty will be void.

Local codes regarding installation vary greatly from one area to another. The National Fire Protection Association, Inc. states in its NFPA 96 latest edition that local codes are the “authority having jurisdiction” when it comes to installation requirements for equipment. Therefore, installations should comply with all local codes.

INSTALLATION

Step 1: Unpack

IMMEDIATELY INSPECT FOR SHIPPING DAMAGE

All containers should be examined for damage before and during unloading. The freight carrier has assumed responsibility for its safe transit and delivery. If damaged equipment is received, either apparent or concealed, a claim must be made with the delivering carrier.

Apparent damage or loss must be noted on the freight bill at the time of delivery. The freight bill must then be signed by the carrier representative (Driver). If the bill is not signed, the carrier may refuse the claim. The carrier can supply the necessary forms.

A request for inspection must be made to the carrier within 15 days if there is concealed damage or loss that is not apparent until after the equipment is uncrated. The carrier should arrange an inspection. Be certain to hold all contents plus all packing material.

1. Uncrate carefully. Report any hidden damage to the freight carrier IMMEDIATELY.
2. Do not remove any tags or labels until unit is installed and working properly.

Step 2: Covert Unit to Use Propane Gas (if necessary)

Each unit is shipped equipped with fixed orifice hoods appropriate for use with natural gas. If propane gas will be used, convert the unit for use with propane gas by the following procedure:

1. Remove the front panel by removing the knobs and screws on the front.
2. For charbroiler and open top models, remove the grates and burners to access the orifices from above. For griddle models, slide the burner toward the rear of the unit to access the orifices (see diagram on page 22), OR remove the griddle plate to access the orifices by removing two nuts at the rear of the unit.
3. Remove the natural gas orifices and install the furnished propane orifices.
4. Re-install the burners.
5. Re-install the front panel.
6. Remove the hex-threaded plug from the pressure regulator. Inside is a removable insert. Pull the insert out, turn it around, and put it back in so that the end with the letters “LP” is now facing you. Re-attach the hex-threaded plug. The pressure regulator is now set for 10" (25.4 cm) water column.
7. Check the pressure.





Provided orifices are size #45 for natural gas and #55 for propane gas. For special gas mixtures, and for altitudes above 2,000 feet, consult factory for appropriate orifice sizes.

Step 3: Connect Gas Supply

All units are shipped from the factory equipped for use with natural gas. If the unit is to be used with propane gas, the orifices must be replaced and the pressure regulator converted (see Step 2 on previous page).

If this equipment is being installed at over 2,000 feet altitude and that information was not specified when ordered, contact the appropriate authorized Southbend Service Representative or the Southbend Service Department. Failure to install with proper orifice sizing will result in poor performance and may void the warranty.

The serial plate is located interior side of the valve panel (see Figure 1 on page 3). It indicates the type of gas the unit is equipped to burn. All Southbend equipment is adjusted at the factory. Check type of gas on serial plate.

These models are design-certified for operation on natural or propane gases. For natural gas, the convertible regulator is set to deliver a 4" W.C. pressure to the manifold. For propane gas, it is set to deliver 10" W.C.

If applicable, the vent line from the gas appliance pressure regulator shall be installed to the outdoors in accordance with local codes or, in the absence of local codes, with the *National Fuel Gas Code, ANSI Z223.1, Natural Gas Installation Code, CAN/CGA-B149.1, or the Propane Installation Code, CAN/CGA-B149.2*, as applicable.

This appliance should be connected **ONLY** to the type of gas for which it is equipped.

An adequate gas supply is imperative. Undersized or low pressure lines will restrict the volume of gas required for satisfactory performance. Fluctuations of more than 25% on natural gas or 10% on propane gas will create problems and affect burner operating characteristics. A 1/8" pressure tap is located on the manifold to measure pressure.

An adequate gas supply line to the unit should be no smaller than the I.D. of the pipe from the unit to which it is connected.

Purge the supply line to clean out dust, dirt, or other foreign matter before connecting the line to the unit.

Use pipe joint compound that is suitable for use with LP gas on all threaded connections.

CAUTION

ALL PIPE JOINTS AND CONNECTIONS MUST BE TESTED THOROUGHLY FOR GAS LEAKS. USE ONLY SOAPY WATER FOR TESTING ON ALL GASES. NEVER USE AN OPEN FLAME TO CHECK FOR GAS LEAKS. ALL CONNECTIONS MUST BE CHECKED FOR LEAKS AFTER THE UNIT HAS BEEN PUT INTO OPERATION. TEST PRESSURE SHOULD NOT EXCEED 14" W.C.

Step 4: Position Unit for Operation

1. Check that the unit is level. The length of each leg is adjustable by screwing the bottom portion of the leg in or out. The unit must be level for proper operation!
2. Check for adequate clearances around the unit (see page 5).
3. Check for adequate ventilation (see page 5).



Step 5: Spread Out Lava-Rock Briquettes (Lava-Rock Charbroilers Only)

This step applies only to the installation of lava-rock charbroiler models. Such models are shipped with the lava-rock briquettes in bags located between the lava-rock grates and the top cooking grids.

1. Lift out the cooking grids to reach the bags of lava-rock briquettes.
2. For each section, open the bag of lava-rock briquettes and spread them evenly on the lava-rock grate. The briquettes must be spread evenly to avoid "hot spots." Discard the empty bags.
3. Reposition the cooking grids above the briquettes.

Step 6: Adjust Air Shutters and Pilot Heights

All units are adjusted at the factory. However, burner air shutters and pilot heights should be checked at installation and adjusted if necessary. On new installations, start with the burner of the unit(s) furthest from the gas input to the manifold. This will purge the system of air.

4. Turn main gas supply "ON."
5. Follow the instructions on pages 12 to 13 light the pilots and burners.
6. If the burner flame is strong but lifting from the burner, loosen the screw on the air shutter and close the shutter a little at a time until the flame settles back onto the burner.

Step 7: Condition Griddle Surface

For griddle and thermostatic-griddle models, the new griddle surface should be carefully tempered and cared for in order to avoid possible damage. To break in a new griddle, first wipe it clean. Next, light all the griddle burners and turn them to low for one hour. Then gradually bring each griddle up to frying temperature. Next, spread three or four ounces of beef suet, or as a substitute, baking soda, to season it. Never allow water on a hot griddle and never wash it with soap and water.



OPERATION

OPERATION

 **DANGER**
EXPLOSION HAZARD

Purchaser of equipment must post in a prominent location, detailed instructions to be followed in the event the operator smells gas. Obtain the instructions from the local gas supplier.

 **CAUTION**

To eliminate gas build up which could result in an explosion, in the event of main burner ignition failure a five minute purge period must be observed prior to re-establishing ignition source.

 **CAUTION**

Top section pilots, when out, do not interrupt the flow of gas to the burners. Consequently, it is the responsibility of the operator to check the ignition of the burners, immediately after burner valve has been turned "ON." Should ignition fail after 10 seconds, turn off burners, wait 5 minutes, and then try again.

LIGHTING AFTER GAS HAS BEEN SHUT OFF

When turning the main gas supply on after the gas supply has been shut off, do the following:

1. Make sure all of the control valves are in the "OFF" position.
2. Turn on the gas supply.
3. Light the pilots as described below.

GRIDDLE & THERMOSTATIC-GRIDDLE MODELS

Each 12"-wide griddle section has a knob on the front panel that directly controls the flow of gas, and so the heat. Turn the knob clockwise to increase the heat; turn it counterclockwise to reduce the heat.

At the end of each day's use, turn all knobs to the "OFF" position. After each period of use, allow the griddle surface to cool normally. After the griddle has cooled, coat the griddle surface with a light film of cooking oil to protect the surface from moisture.

To light the pilot of a griddle section, do the following:

1. Turn all control knobs to the "OFF" position.
2. Light the pilot tube located next to each burner. The pilot flame can be adjusted by turning the screw on the end of the pilot fitting.
3. Turn burner knobs to "HI" position. The burners should have a 1/2" to 5/8" steady blue flame. Adjust if necessary.
4. To turn burners off, turn knob to "OFF" position.





CHARBROILER MODELS

Each 12"-wide charbroiler section has a knob on the front panel that directly controls the flow of gas, and so the heat. Turn the knob clockwise to increase the heat; turn it counterclockwise to reduce the heat.

At the end of each day's use, turn all knobs to the "OFF" position.

To light the pilot of a charbroiler section, do the following:

1. Turn all control knobs to the "OFF" position.
2. Light the pilot tube located next to each burner. The pilot flame can be adjusted by turning the screw on the end of the pilot fitting.
3. Turn burner knobs to "HI" position. The burners should have a 1/2" to 5/8" steady blue flame. Adjust if necessary.
4. To turn burners off, turn knob to "OFF" position.

OPEN-TOP BURNER MODELS

Each 12"-wide open-top burner section has two knobs on the front panel that directly control the flow of gas to the section's two burners, and so control the heat. Turn a knob clockwise to increase the heat; turn it counterclockwise to reduce the heat.

At the end of each day's use, turn all knobs to the "OFF" position.

To light the pilots of an open-top burner section, do the following:

1. Turn all gas valves to the "OFF" position.
2. Check to make sure pilots are in the correct position.
3. Light the pilots.
4. Adjust the pilot flame as necessary.
5. Turn burner knobs to "HI" position. Each burner flame should be steady blue and impinge on the underside of a pot placed on the support grate. Adjust if necessary.
6. To turn burners off, turn knob to "OFF" position.

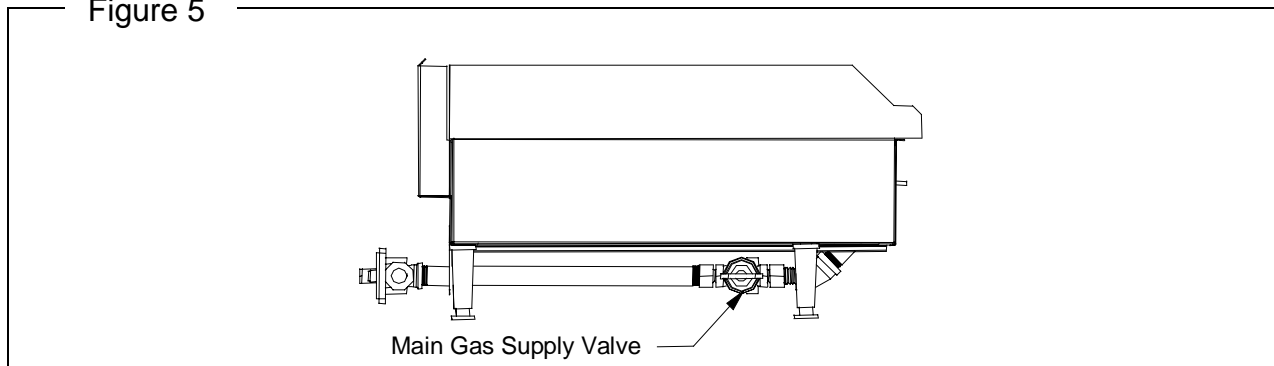
OVERNIGHT SHUTDOWN

Turn knobs to the "OFF" position to turn the burners off.

EXTENDED-PERIOD SHUTDOWN OF THERMOSTATIC GRIDDLE

To shut down a thermostatic griddle for an extended period (or before disconnecting the gas supply), turn all manual gas valves and pilots "OFF," then turn the main gas supply valve to "OFF" (see Figure 5 below).

Figure 5





CLEANING

Southbend equipment is constructed with the best quality materials and is designed to provide durable service when properly maintained. To expect the best performance, your equipment must be maintained in good condition and cleaned daily. Naturally, the frequency and extent of cleaning depends on the amount and degree of usage.

EXTERIOR AND TOP SECTIONS:

1. Keep exposed, cleanable areas of unit clean at all times.

Daily:

- A. Remove, empty, and clean grease drawers and dirt trays.
- B. Clean griddle drain chutes.

Monthly:

- A. Clean around burner air mixers and orifices if lint has accumulated.
- B. Visually assure proper pilot operation.

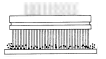
STAINLESS STEEL SURFACES

1. To remove normal dirt, grease and product residue from stainless steel that operates at LOW temperature, use ordinary soap and water (with or without detergent) applied with a sponge or cloth. Dry thoroughly with a clean cloth.
2. To remove grease and food splatter, or condensed vapors, that have BAKED on the equipment, apply cleanser to a damp cloth or sponge and rub cleanser on the metal in the direction of the polishing lines on the metal. Rubbing cleanser, as gently as possible, in the direction of the polished lines will not mar the finish of the stainless steel. NEVER RUB WITH A CIRCULAR MOTION. Soil and burnt deposits which do not respond to the above procedure can usually be removed by rubbing the surface with SCOTCH-BRITE scouring pads or STAINLESS scouring pads. DO NOT USE ORDINARY STEEL WOOL, as any particles left on the surface will rust and further spoil the appearance of the finish. NEVER USE A WIRE BRUSH, STEEL SCOURING PADS (EXCEPT STAINLESS), SCRAPER, FILE OR OTHER STEEL TOOLS. Surfaces which are marred collect dirt more rapidly and become more difficult to clean. Marring also increases the possibility of corrosive attack. Refinishing may then be required.
3. **To remove heat tint** – Darkened areas sometimes appear on stainless steel surfaces where the area has been subjected to excessive heat. These darkened areas are caused by thickening of the protective surface of the stainless steel and are not harmful. Heat tint can normally be removed by the foregoing, but tint which does not respond to this procedure calls for a vigorous scouring in the direction of the polish lines, using SCOTCH-BRITE scouring pads or a STAINLESS scouring pad in combination with a powered cleanser. Heat tint action may be lessened by not applying, or by reducing heat to equipment during slack periods.

BURNERS – GENERAL

Little attention is needed, but if spillage should occur, it may be necessary to clean around pilot areas, air mixer and under burners. Use a wire brush if necessary.

Periodically, burners (particularly open top type) should be removed and cleaned. Allow interior to drain. Dry thoroughly before replacing.



CARE OF GRIDDLES

New griddles should be carefully tempered and cared for in order to avoid possible damage. To break in a new griddle, first wipe it clean. Next, light all the griddle burners and turn them to low for one hour. Then gradually bring each griddle up to frying temperature. Next, spread three or four ounces of beef suet, or as a substitute, baking soda, to season it. Never allow water on a hot griddle and never wash it with soap and water.

Use a Norton Alundum Griddle Brick to clean the griddle. Always remember to heat griddle slowly because quick heat may cause costly damage. Griddle plates cannot be guaranteed against damage due to carelessness. Never place utensils on griddle. Do not overheat griddle above 550°F, as this will cause warpage or breakage.

Do not use any type of steel wool. Small particles may be left on the surface and get into food products. Do not clean spatula by hitting the edge on the griddle plate. Such action will only cut and pit the griddle plate, leaving it rough and hard to clean.

Do not waste gas or abuse equipment by leaving valves at "Full On" position or thermostat at a high temperature if not required. During idle periods, set valves at "Low" position or thermostats to low temperature settings to keep griddle warm. Reset valves or thermostats, as required, for periods of heavy load. Turn valves or thermostats to "OFF" at end of daily operation.



ADJUSTMENTS

! WARNING

ADJUSTMENTS AND SERVICE WORK MAY BE PERFORMED ONLY BY A QUALIFIED TECHNICIAN WHO IS EXPERIENCED IN, AND KNOWLEDGEABLE WITH, THE OPERATION OF COMMERCIAL COOKING EQUIPMENT. HOWEVER, TO ASSURE YOUR CONFIDENCE, CONTACT YOUR AUTHORIZED SERVICE AGENCY FOR RELIABLE SERVICE, DEPENDABLE ADVICE OR OTHER ASSISTANCE, AND FOR GENUINE FACTORY PARTS.

In case of problems in operation at initial installation, check type of gas and manifold pressure and compare with information listed on the serial plate.

GAS PRESSURE REGULATOR

The convertible pressure regulator is factory set at 4" W.C. for natural gas. (To convert for use with propane gas (10" W.C.), follow the procedure on page 9.) To check the manifold pressure:

1. Turn all burner valves to "OFF" position.
2. Turn main gas valve to entire unit off.
3. Remove front panel and locate 1/8" plug in manifold.
4. Remove plug and install a fitting appropriate to connect a manometer.
5. Turn on main gas to unit and light pilots.
6. Turn all burners and ovens to full "ON" position and read manometer.
7. If manometer does not read 4" W.C. for natural gas (or 10" W.C. for propane gas), check the incoming gas line for proper pressure.
8. Remove manometer fitting and replace plug in manifold.
9. Repeat step 5.
10. Replace front panel.

ADJUSTMENTS

TOP PILOTS: NON-AERATED (YELLOW-TIPPED FLAME) TYPE

Outage is often caused by an unstable flame due to over-adjustment to the point where the flame is leaving its port, or "blowing off."

Often, in an effort to improve ignition, the pilots are increased too much and result in this unstable condition.

These pilots are adjusted by inserting the blade of a screwdriver into the slot on the small valve, located on the manifold. The maximum flame size is approximately 3/4" with a slight yellow tip. The first indication of over-adjustment is evident when the yellow tip begins to stream into black streaks and generate carbon. Continued over-adjustment leads to the unstable lifting and blowing condition.

ALL TOP BURNERS

All burners have a primary air adjustment by means of an air shutter on the mixer face.

Loosen screw and rotate mixer cap until a clear, stable blue flame is obtained. The flame should not be yellow tipped nor should it blow off the burner ports.





All orifice sizes and burner rate are properly set at the factory and should not be altered.

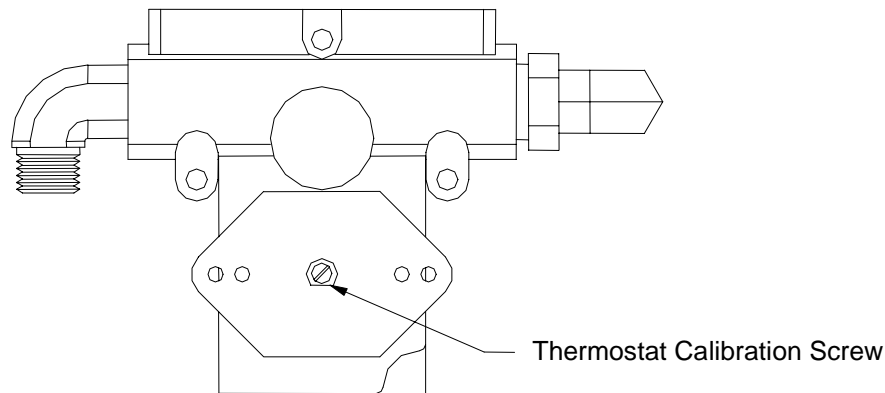
Over-rated burners cause poor burner and pilot performance, resulting in less heat, and wasted gas.

Over-gassed burners DO NOT heat griddles as efficiently as those that are properly adjusted. Such conditions also create "hot spots" on griddles. Floating and unstable burner and pilot flames will result when solid tops are lowered into position because the rear openings of the burner compartment are not adequate to vent the enormous flue products generated by over-gassed burners. The "unburned" gas will ignite at the rear and burn in this section and even up inside the backguard or shelf venting system, causing structural members in this area to deteriorate. Also, some of these hot flue products will vent forward into the manifold compartment resulting in problems with valves and thermostats due to overheating. AGAIN, over-rated burners waste energy and cause service problems.

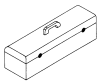
SNAP-ACTION THERMOSTATIC VALVE

Thermostatic-griddle models have snap-action thermostatic valves that are adjusted at the factory. If the griddle surface temperature is different from the thermostat dial setting, adjust the valve (see Figure 6 below).

Figure 6



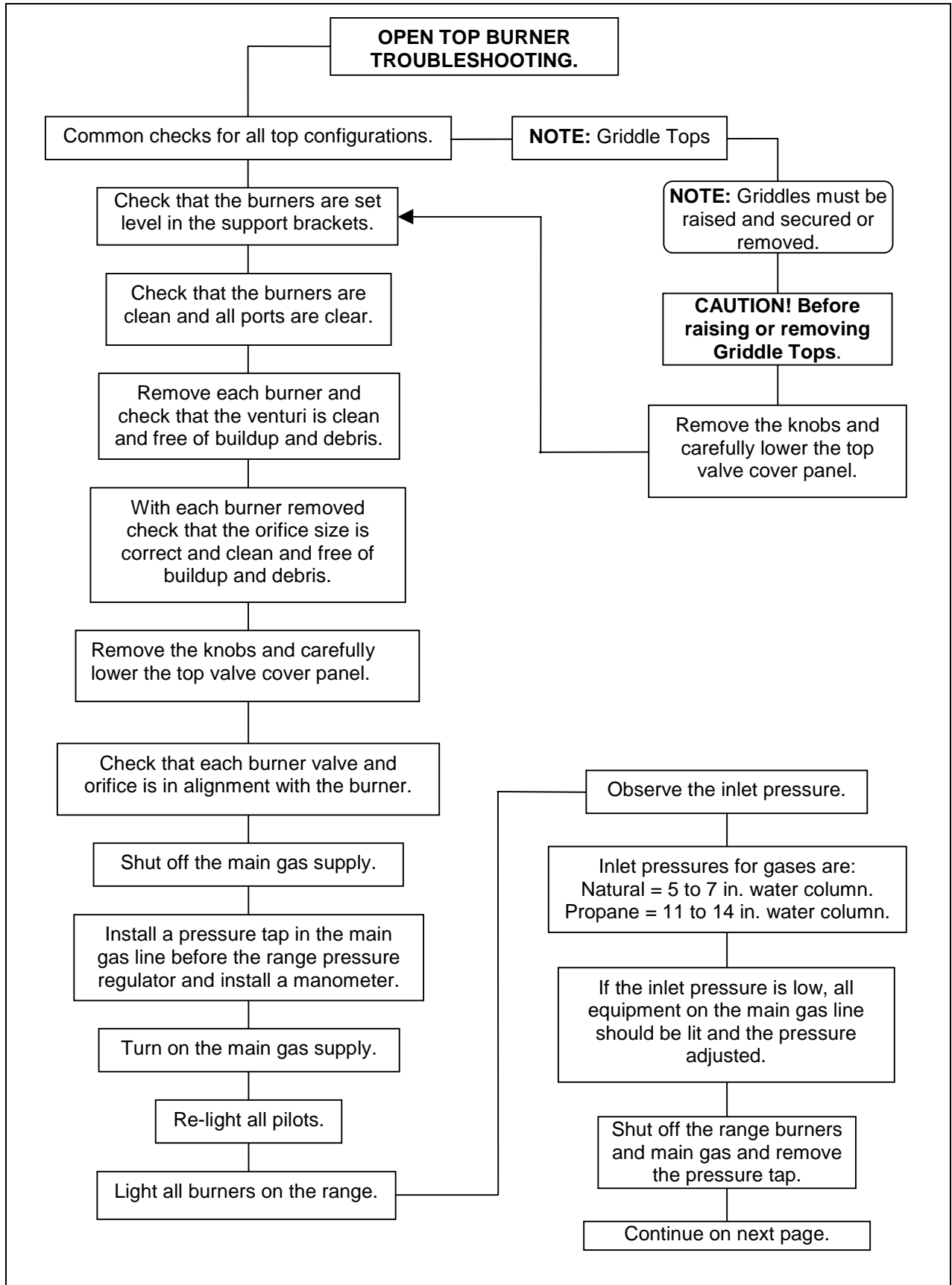
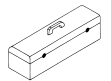
Calibrate the valve using the screw at the base of the stem. Turn the screw clockwise to increase the temperature, or counterclockwise to decrease the temperature.



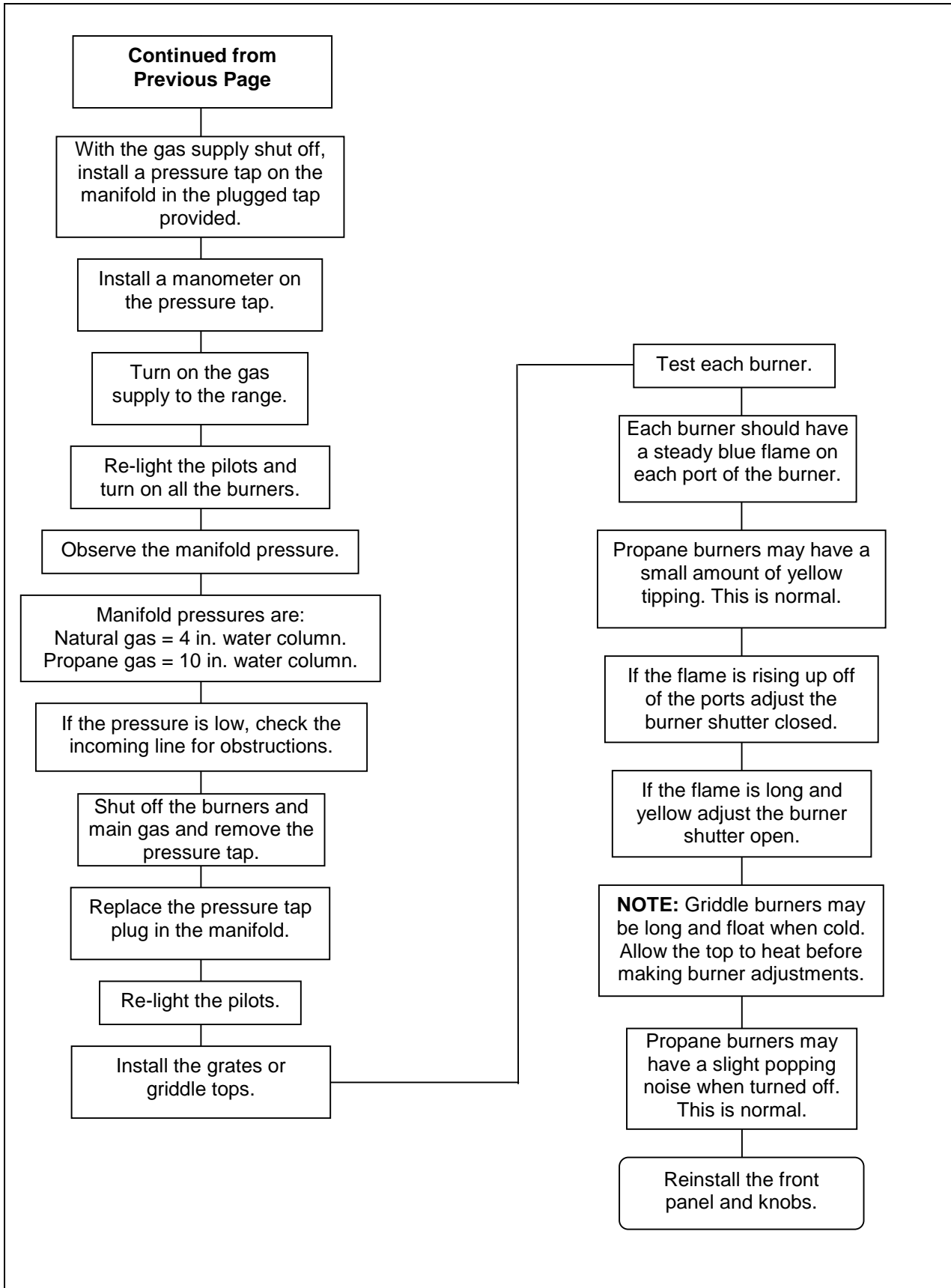
TROUBLESHOOTING

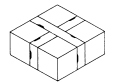
Consult the following table and the flowchart that begins on the following page.

Problem	Look for -
All burners and pilots in unit will not turn on	- Main gas supply to unit is "OFF."
All burners produce excessive carbon deposits	- Incorrect gas type supplied to unit. - Incorrect supply pressure.
Only some burners in a unit produce excessive carbon deposits	- Incorrect orifices. - Primary air not adjusted properly.
Only some pilots produce excessive carbon deposits	- Pilot gas not adjusted properly. - Incorrect pilot orifice.
Top burner will not come on	- Manual valve for top burner in "OFF" position. - Pilot out.
Top section pilot will not stay ignited	- Pilot gas not adjusted properly. - Clogged orifice. - Draft condition. - Improper ventilation system. - Air in gas line.
Lava-rock charbroiler has "hot spots"	- Stacked-up lava-rock briquettes. The briquettes should be spread out evenly.



TROUBLESHOOTING





PARTS

NOTICE

INSTALLATION OF OTHER THAN GENUINE SOUTHBEND PARTS WILL VOID THE WARRANTY ON THIS EQUIPMENT.

The serial plate is located inside of the front panel (see Figure 1 on page 3).

Replacement parts may be ordered either through a Southbend Authorized Parts Distributor or a Southbend Authorized Service Agency.

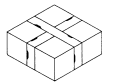
When ordering parts, please supply the Model Number, Serial Number, Part Number, and Description.

For parts not listed, consult a Southbend Authorized Parts Distributor or Southbend Authorized Service Agency. Consult the Southbend Authorized Parts/Service Distributor list for the Authorized Parts supplier in your area. If this list is not available, call Southbend at 1-800-348-2558 to obtain this list.

Index of Parts Diagrams	
Page Number	Description
22	Parts for Griddle Models MDG-24, MDG-36, and MDG-48
24	Parts for Thermostatic-Griddle Models MDGT-24, MDGT-36, and MDGT-48
26	Parts for Charbroiler Models MDC-24, MDCL-24, MDC-36, MDCL-36, MDC-48, and MDCL-48
28	Parts for Open-Top Models MDO-12, MDO-24, and MDO-36

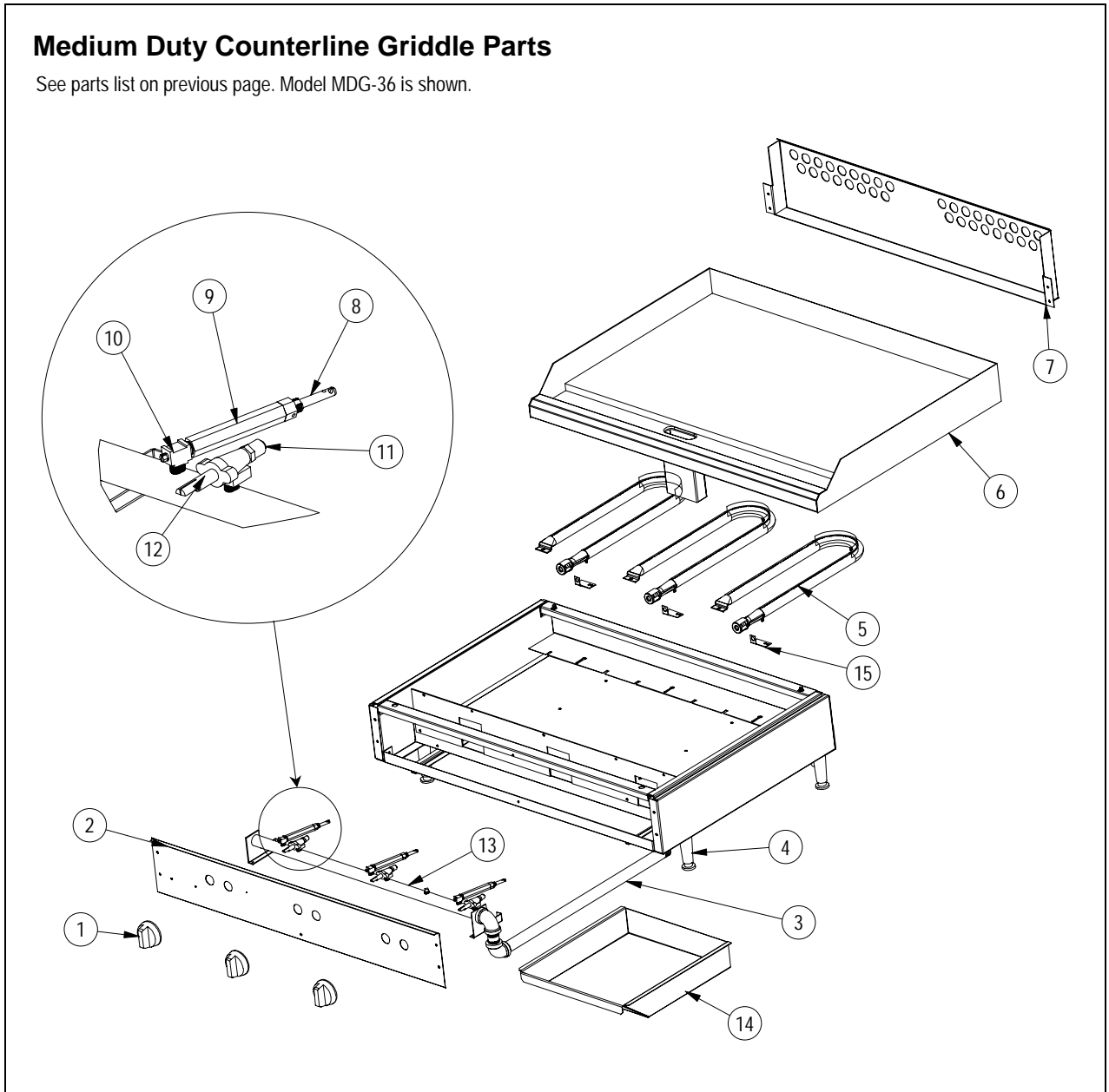


Medium Duty Counterline Griddle Parts			
See drawing on following page.			
Key	Part Number	Qty	Description
1	1177704	**	Knob
2	1178840	1	Front panel, 24" (for Model MDG-24)
	1178842	1	Front panel, 36" (for Model MDG-36)
	1178843	1	Front panel, 48" (for Model MDG-48)
3	1178826	1	Tailpipe
4	1172857	4	Legs (set of four)
5	1178836	**	Burner
6	1178801	1	Griddle weld assembly, 24" (for Model MDG-24)
	1178802	1	Griddle weld assembly, 36" (for Model MDG-36)
	1178803	1	Griddle weld assembly, 48" (for Model MDG-48)
7	1178890	1	Flue riser, 24" (for Model MDG-24)
	1178891	1	Flue riser, 36" (for Model MDG-36)
	1178892	1	Flue riser, 48" (for Model MDG-48)
8	1038099	**	Pilot
9	1178816	**	Pilot extension
10	1178821	**	Pilot adjustment valve
11	1008745	**	Orifice, natural #45
	1008755	**	Orifice, propane #55
12	1178202	**	Valve
13	1178845	1	Manifold weld assembly, 24" (for Model MDG-24)
	1178895	1	Manifold weld assembly, 36" (for Model MDG-36)
	1178896	1	Manifold weld assembly, 48" (for Model MDG-48)
14	1178886	1	Grease drawer, 12" (for Models MDG-36 and MDG-48)
	1178923	1	Grease drawer, 6" (for Model MDG-24)
15	1178817	**	Pilot bracket
*	1178815	1	Pressure regulator, nat/LP
*	1181735	1	Poly panel, 24" (for Model MDG-24)
	1181736	1	Poly panel, 36" (for Model MDG-36)
	1181737	1	Poly panel, 48" (for Model MDG-48)
* Not shown on drawing.			
** One per griddle section (total of two for a Model MDG-24, three for a Model MDG-36, or four for a Model MDG-48).			



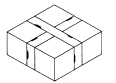
Medium Duty Counterline Griddle Parts

See parts list on previous page. Model MDG-36 is shown.



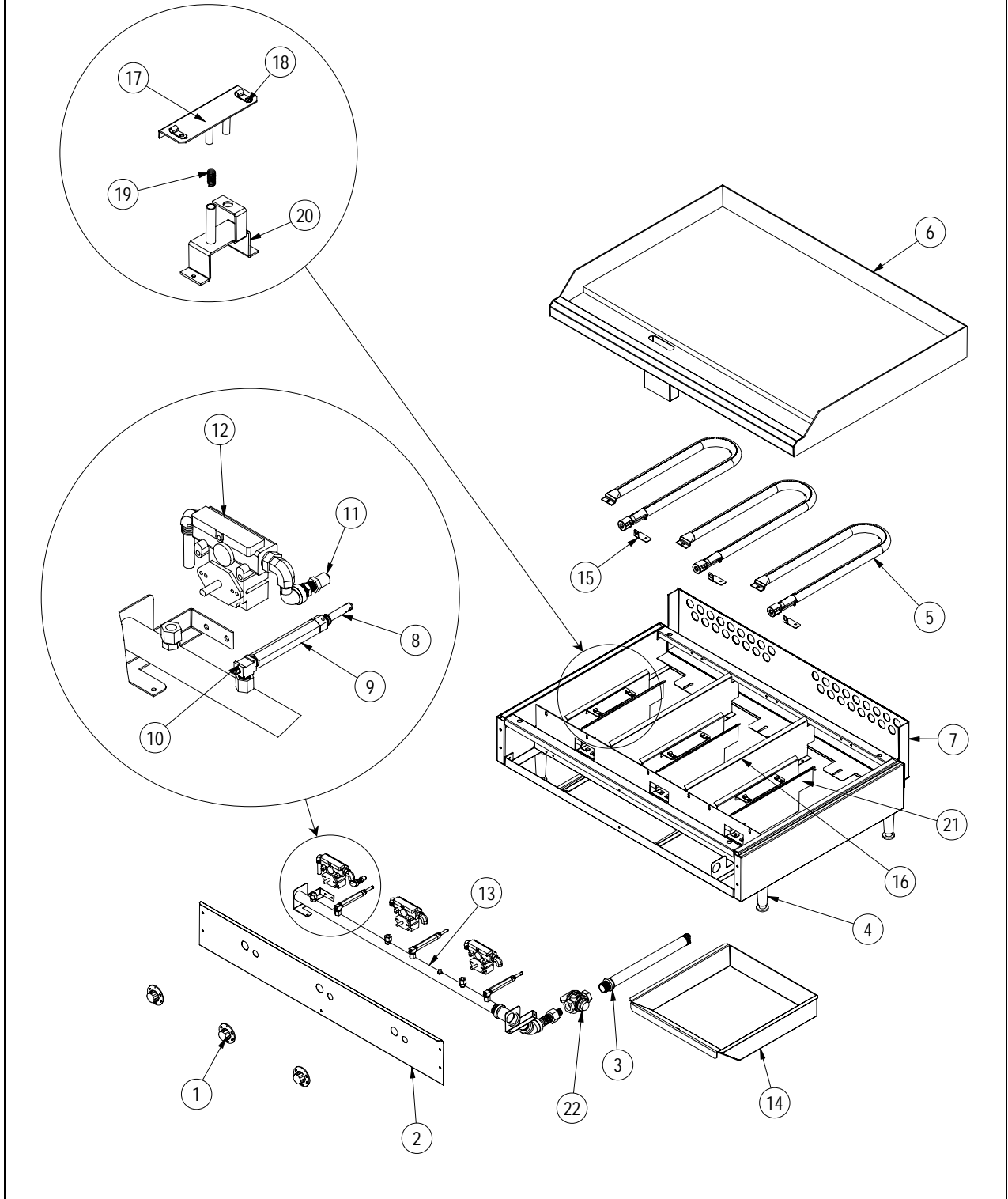


Medium Duty Counterline Thermostatic-Griddle Parts			
See drawing on following page.			
Key	Part Number	Qty	Description
1	1182586	**	Knob
2	1178988	1	Front panel, 24" (for Model MDGT-24)
	1181400	1	Front panel, 36" (for Model MDGT-36)
	1181408	1	Front panel, 48" (for Model MDGT-48)
3	1163506	1	Tailpipe
4	1172857	4	Legs (set of four)
5	1178836	**	Burner
6	1178982	1	Griddle weld assembly, 24" (for Model MDGT-24)
	1178996	1	Griddle weld assembly, 36" (for Model MDGT-36)
	1181404	1	Griddle weld assembly, 48" (for Model MDGT-48)
7	1178890	1	Flue riser, 24" (for Models MDG-24 & MDGT-24)
	1178891	1	Flue riser, 36" (for Models MDG-36 & MDGT-36)
	1178892	1	Flue riser, 48" (for Models MDG-48 & MDGT-48)
8	1038099	**	Pilot
9	1178816	**	Pilot extension
10	1178821	**	Pilot adjustment valve
11	1008745	**	Orifice, natural #45
	1008755	**	Orifice, propane #55
12	1182553	**	Valve
13	1178986	1	Manifold weld assembly, 24" (for Model MDGT-24)
	1178998	1	Manifold weld assembly, 36" (for Model MDGT-36)
	1181406	1	Manifold weld assembly, 48" (for Model MDGT-48)
14	1178886	1	Grease drawer, 12" (for Models MDG-36, MDGT-36, MDG-48, and MDGT-48)
	1178923	1	Grease drawer, 6" (for Models MDG-24 and MDGT-24)
15	1178817	**	Pilot bracket
16	1178991	***	Divider, cavity
17	1181498	**	Probe support weld assembly
18	1178149	**	Clamp, probe
19	1179932	**	Spring
20	1180581	**	Probe support base weld assembly
21	1180582	**	Heat shield
22	1-5771	1	Manual gas supply on-off valve
*	1178815	1	Pressure regulator, nat/LP
*	1178990	1	Poly panel, 24" (for Model MDGT-24)
	1181402	1	Poly panel, 36" (for Model MDGT-36)
	1181410	1	Poly panel, 48" (for Model MDGT-48)
<p>* Not shown on drawing. ** One per griddle section (total of two for a Model MDGT-24, three for a Model MDGT-36, or four for a Model MDGT-48). *** One between each griddle section (one for a Model MDGT-24, two for a Model MDGT-36, or three for a Model MDGT-48).</p>			



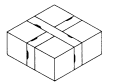
Medium Duty Counterline Thermostatic-Griddle Parts

See parts list on previous page. Model MDGT-36 is shown.



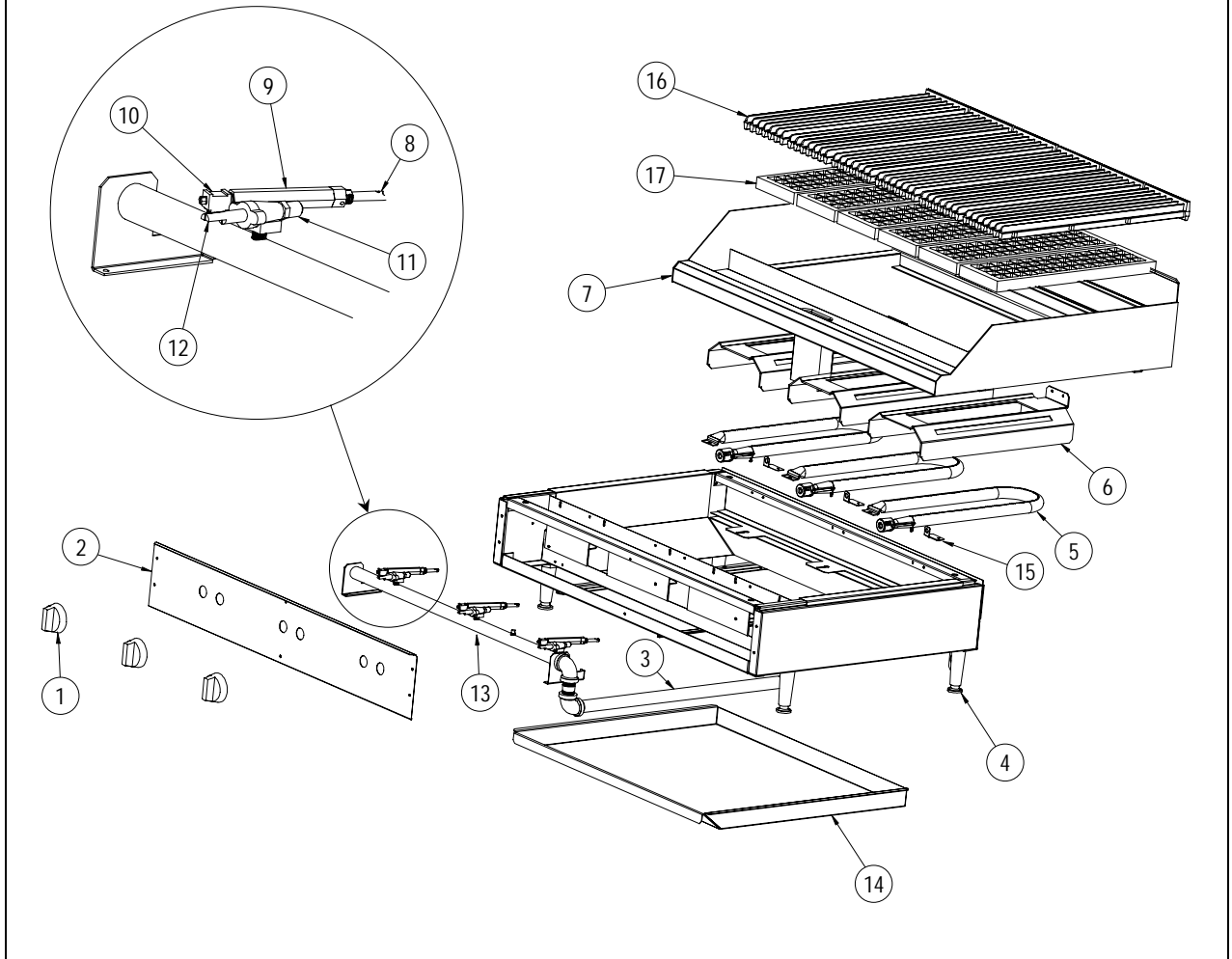


Medium Duty Counterline Charbroiler Parts			
See drawing on following page.			
Key	Part Number	Qty	Description
1	1177704	**	Knob
2	1178840	1	Front panel, 24" (for Models MDC-24 and MDCL-24)
	1178842	1	Front panel, 36" (for Models MDC-36 and MDCL-36)
	1178843	1	Front panel, 48" (for Models MDC-48 and MDCL-48)
3	1178826	1	Tailpipe
4	1172857	4	Legs (set of four)
5	1178836	**	Burner
6	1178902	**	Charbroiler radiant
7	1182659	1	Charbroiler assembly, 24" (for Models MDC-24 and MDCL-24)
	1182676	1	Charbroiler assembly, 36" (for Models MDC-36 and MDCL-36)
	1182677	1	Charbroiler assembly, 48" (for Models MDC-48 and MDCL-48)
8	1038099	**	Pilot
9	1178816	**	Pilot extension
10	1178821	**	Pilot adjustment valve
11	1008745	**	Orifice, natural #45
	1008755	**	Orifice, propane #55
12	1178202	**	Valve
13	1178845	1	Manifold weld assembly, 24" (for Models MDC-24 and MDCL-24)
	1178895	1	Manifold weld assembly, 36" (for Models MDC-36 and MDCL-36)
	1178896	1	Manifold weld assembly, 48" (for Models MDC-48 and MDCL-48)
14	1178886	1	Grease drawer, 12" (for Models MDC-24 and MDCL-24)
	1178841	1	Grease drawer, 26" (for Models MDC-36, MDCL-36, MDC-48, and MDCL-48)
15	1178817	**	Pilot bracket
16	1172781	***	Grid, charbroiler
17	1182657	***	Grate, lava-rock (for MDCL models only)
*	1173193	**	Briquettes, bag (for MDCL models only)
*	1178815	1	Pressure regulator, nat/LP
*	1181735	1	Poly panel, 24" (for Models MDC-24 and MDCL-24)
	1181736	1	Poly panel, 36" (for Models MDC-36 and MDCL-36)
	1181737	1	Poly panel, 48" (for Models MDC-48 and MDCL-48)
* Not shown on drawing.			
** One per charbroiler section (total of two for a Model MDC-24 or MDCL-24, three for a Model MDC-36 or MDCL-36, or four for a Model MDC-48 or MDCL-48).			
*** Two per charbroiler section (total of four for a Model MDC-24 or MDCL-24, six for a Model MDC-36 or MDCL-36, or eight for a Model MDC-48 or MDCL-48).			



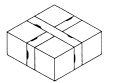
Medium Duty Counterline Charbroiler Parts

See parts list on previous page. Model MDCL-36 is shown.



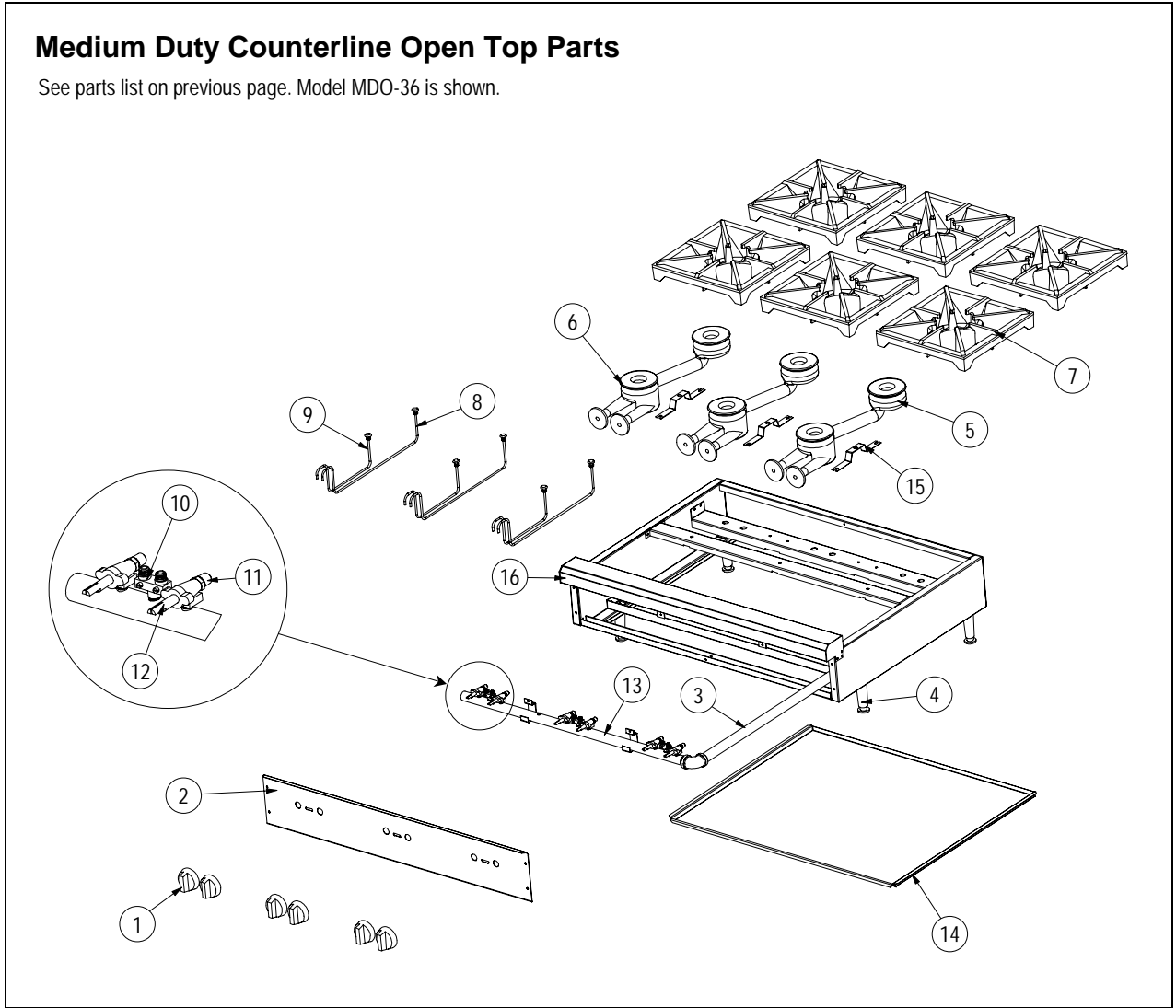


Medium Duty Counterline Open Top Parts			
See drawing on following page.			
Key	Part Number	Qty	Description
1	1177704	***	Knob
2	1178971	1	Front panel, 12" (for Model MDO-12)
	1178969	1	Front panel, 24" (for Model MDO-24)
	1178970	1	Front panel, 36" (for Model MDO-36)
3	1178944	1	Tailpipe
4	1172857	4	Legs (set of four)
5	1177439	**	Burner, rear
6	1177111	**	Burner, front
7	1181100	***	Grate, counter top
8	1178942	**	Pilot, rear
9	1178941	**	Pilot, front
10	1166004	***	Pilot adjustment valve
11	1008745	***	Orifice, natural #45
	1008755	***	Orifice, propane #55
12	1178202	***	Valve
13	1178960	1	Manifold weld assembly, 12" (for Model MDO-12)
	1178936	1	Manifold weld assembly, 24" (for Model MDO-24)
	1178959	1	Manifold weld assembly, 36" (for Model MDO-36)
14	1178966	1	Grease drawer, 12" (for Model MDO-12)
	1178973	1	Grease drawer, 24" (for Model MDO-24)
	1178965	1	Grease drawer, 36" (for Model MDO-36)
15	1178940	**	Pilot bracket
16	1178958	1	Front rail, 12" (for Model MDO-12)
	1178934	1	Front rail, 24" (for Model MDO-24)
	1178957	1	Front rail, 36" (for Model MDO-36)
*	1178815	1	Pressure regulator, nat/LP
*	1181738	1	Poly panel, 12" (for Model MDO-12)
	1181739	1	Poly panel, 24" (for Model MDO-24)
	1181740	1	Poly panel, 36" (for Model MDO-36)
* Not shown on drawing.			
** One per open-top section (total of one for a Model MDO-12, two for a Model MDO-24, or three for a Model MDO-36).			
*** Two per open-top section (total of two for a Model MDO-12, four for a Model MDO-24, or six for a Model MDO-36).			



Medium Duty Counterline Open Top Parts

See parts list on previous page. Model MDO-36 is shown.







MEDIUM DUTY COUNTERLINE

A product with the Southbend name incorporates the best in durability and low maintenance. We all recognize, however, that replacement parts and occasional professional service may be necessary to extend the useful life of this unit. When service is needed, contact a Southbend Authorized Service Agency, or your dealer. To avoid confusion, always refer to the model number, serial number, and type of your unit.



Southbend
1100 Old Honeycutt Road, Fuquay-Varina, NC 27526
(800) 348-2558 or (919) 552-9161 • FAX (800) 348-2558 or (919) 552-9798