

JetStar®

COUNTER POPCORN POPPER

MODEL
39 & 86 Series

Installation and Operation Instructions

2M-Y8397 Rev. O 4/28/11

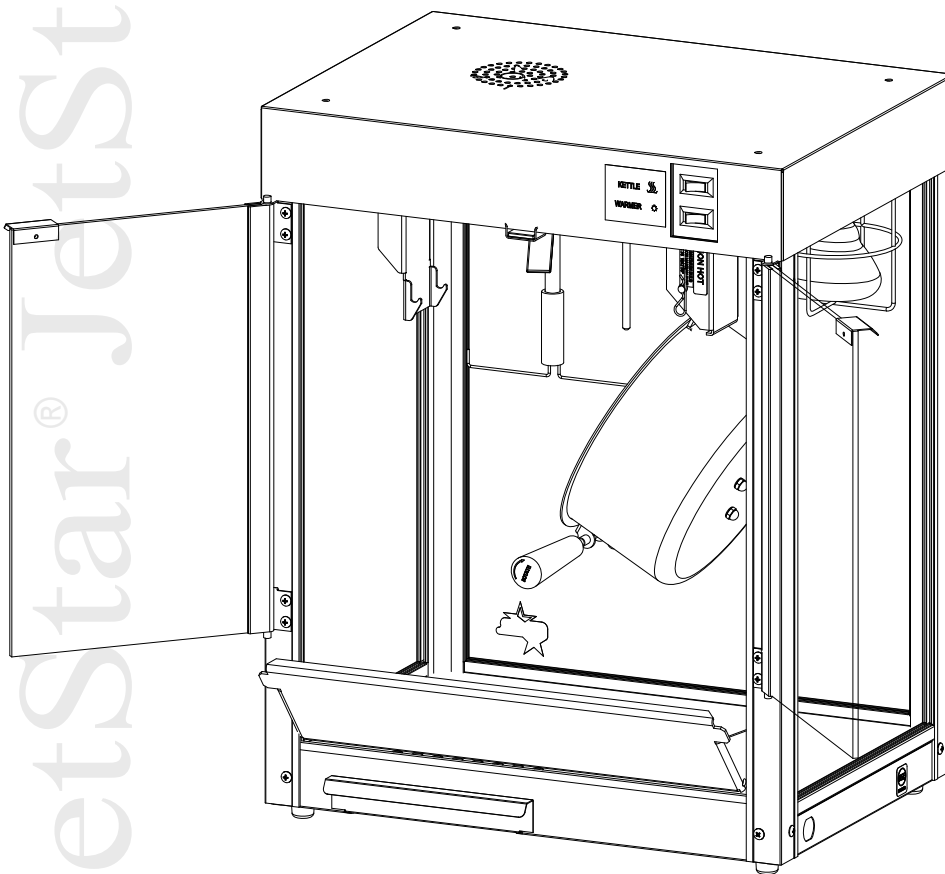

39 Series

IL1225



SAFETY SYMBOL



These symbols are intended to alert the user to the presence of important operating and maintenance instructions in the manual accompanying the appliance.

RETAIN THIS MANUAL FOR FUTURE REFERENCE NOTICE

Using any part other than genuine Star factory supplied parts relieves the manufacturer of all liability.

Star reserves the right to change specifications and product design without notice. Such revisions do not entitle the buyer to corresponding changes, improvements, additions or replacements for previously purchased equipment.

Due to periodic changes in designs, methods, procedures, policies and regulations, the specifications contained in this sheet are subject to change without notice. While Star International Holdings Inc., Company exercises good faith efforts to provide information that is accurate, we are not responsible for errors or omissions in information provided or conclusions reached as a result of using the specifications. By using the information provided, the user assumes all risks in connection with such use.

MAINTENANCE AND REPAIRS

Contact your local authorized service agent for service or required maintenance.

Please record the model number, serial number, voltage and purchase date in the area below and have it ready when you call to ensure a faster service.

Model No. _____

Serial No. _____

Voltage _____

Purchase Date _____

Authorized Service Agent Listing

Reference the listing provided with the unit

or

for an updated listing go to:

Website: www.star-mfg.com
E-mail Service@star-mfg.com

Service Help Desk

Business Hours: 8:00 am to 4:30 p.m. Central Standard Time

Telephone: (314) 678-6303

Fax: (314) 781-2714

E-mail Parts@star-mfg.com
Service@star-mfg.com
Warranty@star-mfg.com

Website: www.star-mfg.com

Mailing Address: Star International Holdings Inc., Company
10 Sunnen Drive
St. Louis, MO 63143
U.S.A

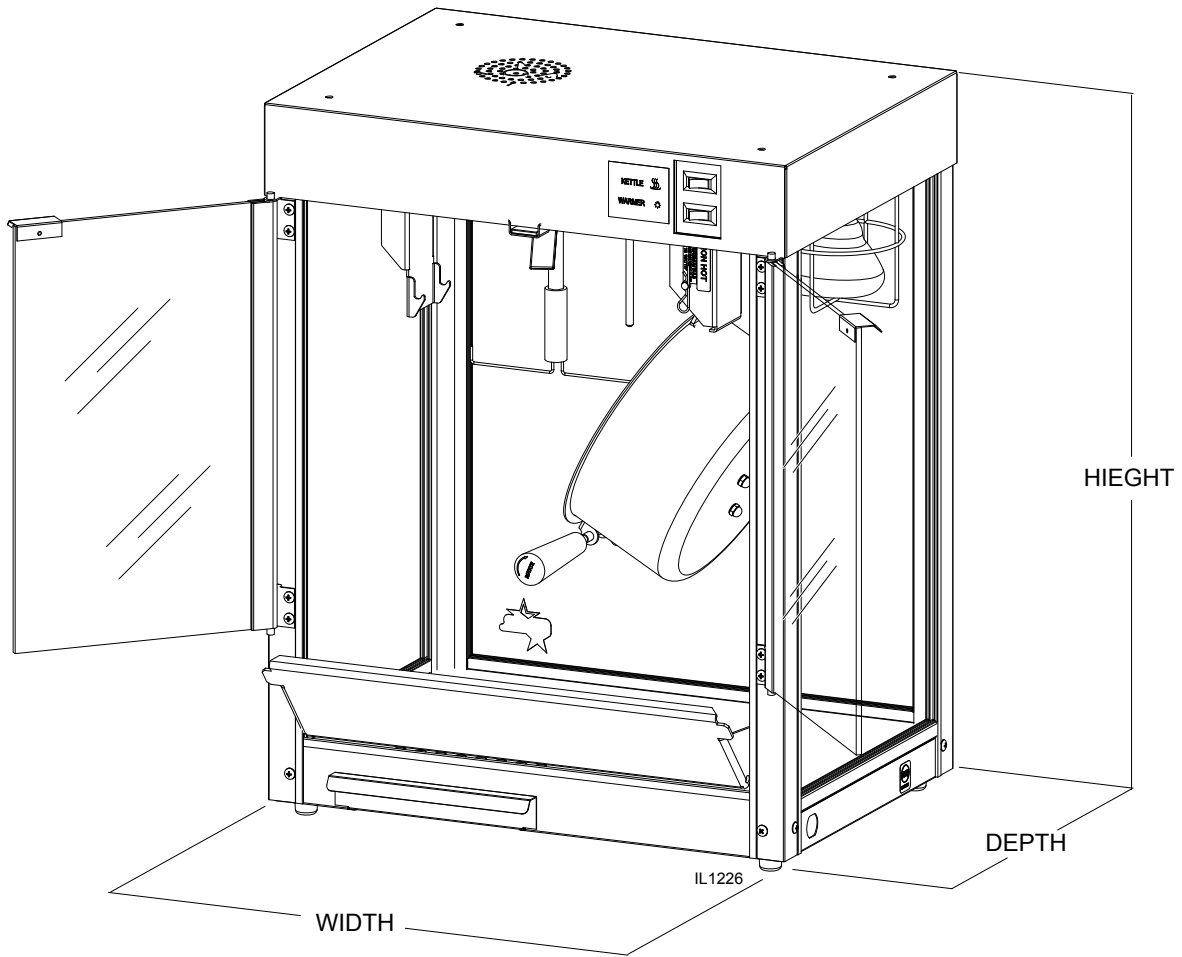

SPECIFICATIONS										
Model	Electrical			Cord	Size			Weight		
	Voltage	Amps	Watts		Width	Depth	Height	Installed	Shipped	
39 SERIES										
8C-39-A-120V	120V	10	1197	NEMA 5-15P	19.5" 49.5 cm	14.25" 36.2 cm	25.125" 63.8 cm	45 lbs 20.41 kg	56 lbs 25.4 kg	
8C-39-A-240V	240V	4.8	1147	NEMA 6-15P						
8C-39-A-240VE	230V	4.8	1100	CEE7/II						
8C-39D-A-120V	120V	10	1197	NEMA 5-15P	21" 53.3 cm					
8C-39D-A-230CE	230V	4.8	1100	CEE7/II						
8C-39D-A-240V	240V	4.8	1147	NEMA 6-15P						
8C-39D-A-240VE	230V	4.8	1100	CEE7/II	19.5" 49.5 cm					
8C-39R-A-120V	120V	10	1197	NEMA 5-15P						
8C-39R-A-230CE	230V	4.8	1100	CEE7/II						
8C-39S-A-120V	120V	10	1197	NEMA 5-15P						
8C-39S-A-240V	240V	4.8	1147	NEMA 6-15P						
8C-39S-A-240VE	230V	4.8	1100	CEE7/II						
8C-39S-AS-120V	120V	10	1197	NEMA 5-15P						
8C-39S-GWP-120V	120V	10	1197							
86 SERIES										
8C-86S-120V	120V	10	1197	NEMA 5-15P		19.5" 49.5 cm	14.25 36.2 cm	30.5" 77.5 cm	54 lbs 24.5 kg	65 lbs 29.5 kg
8C-86SS-120V										
86S-230CE	230V	4.8	1100	CEE7/II						
86SS-230CE										

FEATURES

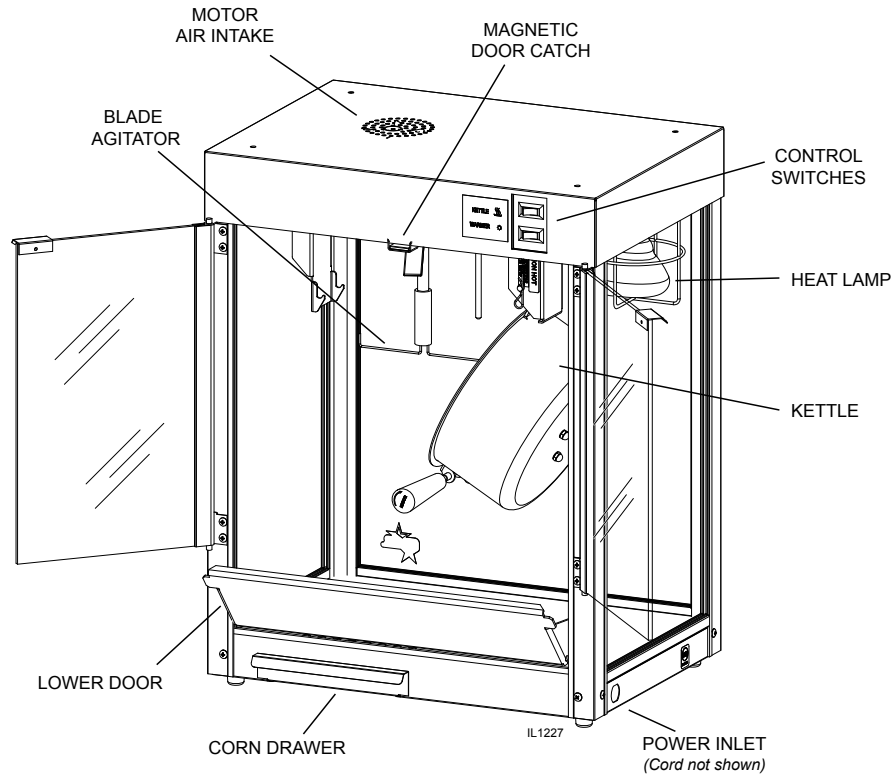

CAUTION

This equipment is designed and sold for commercial use only by personnel trained and experienced in its operation and is not sold for consumer use in and around the home nor for use directly by the general public in food service locations. For equipment to be used by the general public, please contact the factory.

Before using your new equipment, read and understand all the instructions & labels associated with the unit prior to putting it into operation. Make sure all people associated with its use understand the units operation & safety before they use the unit.

All shipping containers should be checked for freight damage both visible and concealed. This unit has been tested and carefully packaged to insure delivery of your unit in perfect condition. If equipment is received in damaged condition, either apparent or concealed, a claim must be made with the delivering carrier.

Concealed damage or loss - if damage or loss is not apparent until after equipment is unpacked, a request for inspection of concealed damage must be made with carrier within 15 days. Be certain to retain all contents plus external and internal packaging materials for inspection. The carrier will make an inspection and will supply necessary claim forms.

GENERAL INSTALLATION INSTRUCTIONS

Each machine has been properly wired and inspected at the factory for operation on the voltage and type of current specified on the nameplate.

WARNING

DO NOT CONNECT TO ANY OTHER TYPE OF CURRENT OR THE MACHINE WILL BE SERIOUSLY DAMAGED.

120 VOLT MACHINES

Machines with a nameplate stamped 120V are equipped for operation on 120 volt 60 hertz AC single phase service and must be connected to a 3 wire grounded, polarized receptacle.

230 VOLT MACHINES

Machines with a nameplate stamped 230CE are equipped for operation on 230 volt 50 hertz AC single phase service and must be connected to a 3 wire grounded receptacle.

DISPLAY SIGN

The display sign is shipped inside the cabinet. It can be located on the front glass or on the rear doors. If installed on the rear doors, cut the sign after installation to allow the doors to open.

GENERAL OPERATING INSTRUCTIONS



CAUTION

The motor air intake hole located on top of the machine must be clear of any obstructions.
DO NOT COVER THIS AIR VENT HOLE AS SERIOUS MOTOR DAMAGE WILL RESULT.

Make sure the corn drawer is in place on the machine before starting the popping cycle. With all switches in the "OFF" (0) position, proceed in the following sequence to pop corn:

1. Turn "ON" (1) the corn warming switch / lamp.
2. Turn "ON" (1) the kettle / motor switch. Allow six or seven minutes to pre-heat the kettle. Thermostat adjustments should not be necessary as it has been preset at the factory for the correct popping temperature.
3. Corn and oil measuring cups are supplied with your machine. Pour a level measuring cup of oil (two ounces) in kettle. Add 6 ounces of raw corn for the 39 Series models or 8 ounces of raw corn for the 86S Series models and 1/2 teaspoon of popcorn salt. Vary the amount of salt and oil to suit taste. If desired, salt may be added after the corn is popped.
4. When the corn stops popping (about 2 1/2 minutes), dump the kettle immediately by turning the handle clockwise approximately 90 degrees to release latch. Recharge as quickly as possible. Screen out unpopped kernels over the perforated section of the corn pan.
5. Turn the kettle switch off (0) when the desired amount of popping is completed.



CAUTION

DO NOT LEAVE THE KETTLE SWITCH "ON" (1) WHEN THE MACHINE IS NOT IN USE.

DO NOT IMMERSE KETTLE IN WATER OR ALLOW WATER TO COME IN CONTACT WITH THE HEATING ELEMENT.

POPPING CORN IN DRY KETTLE IS NOT RECOMMENDED.

KEEPING THE POPPING UNIT CLEAN

After each popping period, wipe the inside and outside of the kettle while it is warm (not hot) with a clean cloth. This is important to keep salt, seasoning, oil from forming a carbonized material which not only lowers popping efficiency but can cause excessive smoking or damage the kettle. For retaining the high luster on the stainless steel kettle shell and lids, use a non-abrasive standard stainless steel cleaner when the kettle is cold. Use a damp cloth and a warm mild soap solution to clean the clear glass and plastic surfaces.

TO REMOVE KETTLE:

Allow kettle to cool or use heat insulated gloves to remove a hot kettle. Turn off the kettle switch. Disconnect the twist lock cap at the end of the kettle conduit, turn kettle handle clockwise 90 degrees to unlatch the kettle. Remove the hitch pin clip from the kettle hinge pin, hold the kettle and pull out the hinge pin. The kettle can now be removed from the unit. Do not place the kettle in water as this will damage the electrical assembly.

MAINTENANCE AND REPAIRS

Contact the factory, a service representative or a local service company for service or required maintenance.

THOROUGHLY INSPECT YOUR UNIT ON ARRIVAL

This unit has been tested for proper operation before leaving our plant to insure delivery of your unit in perfect condition. However, there are instances in which the unit may be damaged in transit. In the event you discover any type of damage to your product upon receipt, you must immediately contact the transportation company who delivered the item to you and initiate your claim with same. If this procedure is not followed, it may affect the warranty status of the unit.

LIMITED EQUIPMENT WARRANTY

All workmanship and material in Star products have a one (1) year limited warranty on parts & labor in the United States and Canada. Such warranty is limited to the original purchaser only and shall be effective from the date the equipment is placed in service. Star's obligation under this warranty is limited to the repair of defects without charge, by the factory authorized service agency or one of its sub-agencies. Models that are considered portable (*see below*) should be taken to the closest Star service agency, transportation prepaid.

- > Star will not assume any responsibility for loss of revenue.
- > On all shipments outside the United States and Canada, see International Warranty.
- * The warranty period for the Ultra-Max, Hot Plates, Griddles, Charbroilers is (3) years parts & labor.
- * The warranty period for the Star-Max, Charbroilers, Griddles, Hot Plates, Fryers & Finishing Oven is (2) years parts & labor.
- * The warranty period for the JetStar six (6) ounce & Super JetStar eight (8) ounce series popcorn machines is two (2) years.
- * The warranty period for the Chrome-Max Griddles is five (5) years on the griddle surface. See detailed warranty provided with unit.
- * The warranty period for Teflon/Dura-Tec coatings is one year under normal use and reasonable care. This warranty does not apply if damage occurs to Teflon/Dura-Tec coatings from improper cleaning, maintenance, use of metallic utensils, or abrasive cleaners, abrasive pads, product identifiers and point-of-sale attachments, or any other non-food object that comes in continuous contact with the roller coating. This warranty does not apply to the "non-stick" properties of such materials.
- > This warranty does not apply to "Special Products" but to regular catalog items only. Star's warranty on "Special Products" is six (6) months on parts and ninety (90) days on labor.
- > This warranty does not apply to any item that is disassembled or tampered with for any purpose other than repair by a Star Authorized Service Center or the Service Center's sub-agency.
- > This warranty does not apply if damage occurs from improper installation, misuse, wrong voltage, wrong gas or operated contrary to the Installation and Operating instructions.
- > This warranty is not valid on Conveyor Ovens *unless* a "start-up/check-out" has been performed by a Factory Authorized Technician.

PARTS WARRANTY

Parts that are sold to repair out of warranty equipment are warranted for ninety (90) days. The part only is warranted, the labor to replace the part is **NOT** warranted.

SERVICES NOT COVERED BY WARRANTY

1. Travel time and mileage rendered beyond the 50 mile radius limit
2. Mileage and travel time on portable equipment (*see below*)
3. Labor to replace such items that can be replaced easily during a daily cleaning routine, i.e; removable kettles on fryers, knobs, grease drawers on griddles, etc.
4. Installation of equipment
5. Damages due to improper installation
6. Damages from abuse or misuse
7. Operated contrary to the Operating and Installation Instructions
8. Cleaning of equipment
9. Seasoning of griddle plates
10. Voltage conversions
11. Gas conversions
12. Pilot light adjustment
13. Miscellaneous adjustments
14. Thermostat calibration and by-pass adjustment
15. Resetting of circuit breakers or safety controls or reset buttons
16. Replacement of bulbs
17. Replacement of fuses
18. Repair of damage created during transit, delivery, & installation OR created by acts of God

PORTABLE EQUIPMENT

Star will not honor service bills that include travel time and mileage charges for servicing any products considered "Portable" including items listed below. These products should be taken to the Service Agency for repair:

- * The Model 510FD, 510FF Fryer.
- * The Model 526TOA Toaster Oven.
- * The Model J4R, 4 oz. Popcorn Machine.
- * The Model 518CMA & 526CMA Cheese Melter.
- * The Model 12MC & 15MC & 18MCP Hot Food Merchandisers.
- * The Model 12NCPW & 15NCPW Nacho Chip/Popcorn Warmer.
- * All Hot Dog Equipment **except Roller Grills & Drawer Bun Warmers.**
- * All Nacho Cheese Warmers **except Model 11WLA Series Nacho Cheese Warmer.**
- * All Condiment Dispensers **except the Model HPD & SPD Series Dispenser.**
- * All Specialty Food Warmers **except Model 130R, 11RW Series, and 11WSA Series.**
- * All QCS/RCS Series Toasters **except Model QCS3 & RCS3 Series.**
- * All Fast Steamer Models **except Direct Connect Series.**

ALL:

- * Pop-Up Toasters
- * Butter Dispensers
- * Pretzel Merchandisers
(Model 16PD-A Only)
- * Pastry Display Cabinets
- * Nacho Chip Merchandisers
- * Accessories of any kind
- * Sneeze Guards
- * Pizza Ovens
(Model PO12 Only)
- * Heat Lamps
- * Pumps-Manual

The foregoing warranty is in lieu of any and all other warranties expressed or implied and constitutes the entire warranty.

FOR ASSISTANCE

Should you need any assistance regarding the Operation or Maintenance of any Star equipment; write, phone, fax or email our Service Department. In all correspondence mention the Model number and the Serial number of your unit, and the voltage or type of gas you are using.

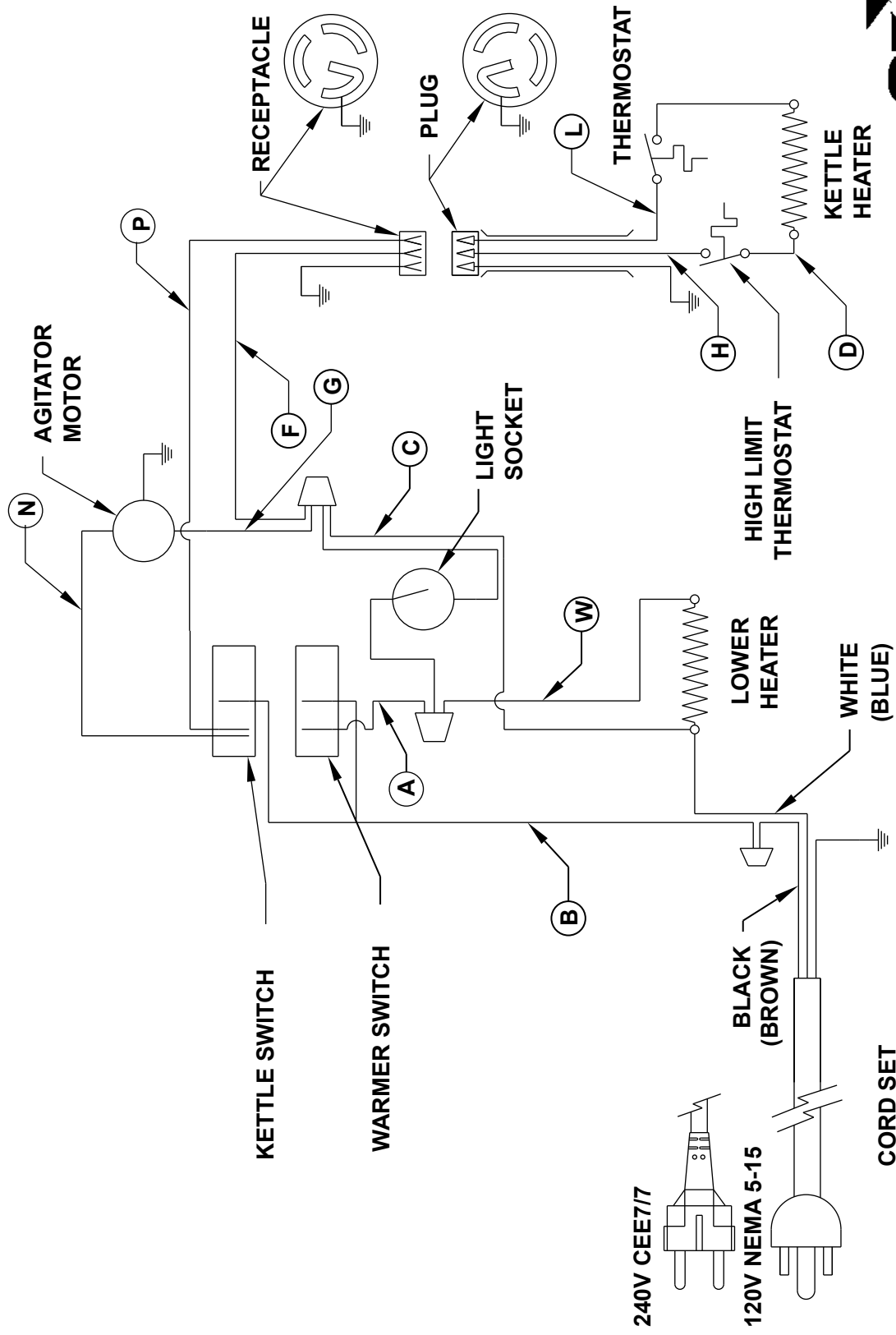

MODEL: WIRE DIAGRAM, 39A, 86S

THIS DRAWING CONTAINS INFORMATION CONFIDENTIAL TO STAR MFG. INT'L. INC.
 NO REPRODUCTION OR DISCLOSURE OF ITS CONTENTS IS PERMITTED.

STAR MANUFACTURING INTERNATIONAL INC.
 SK1148
 Rev C
 02/28/2005

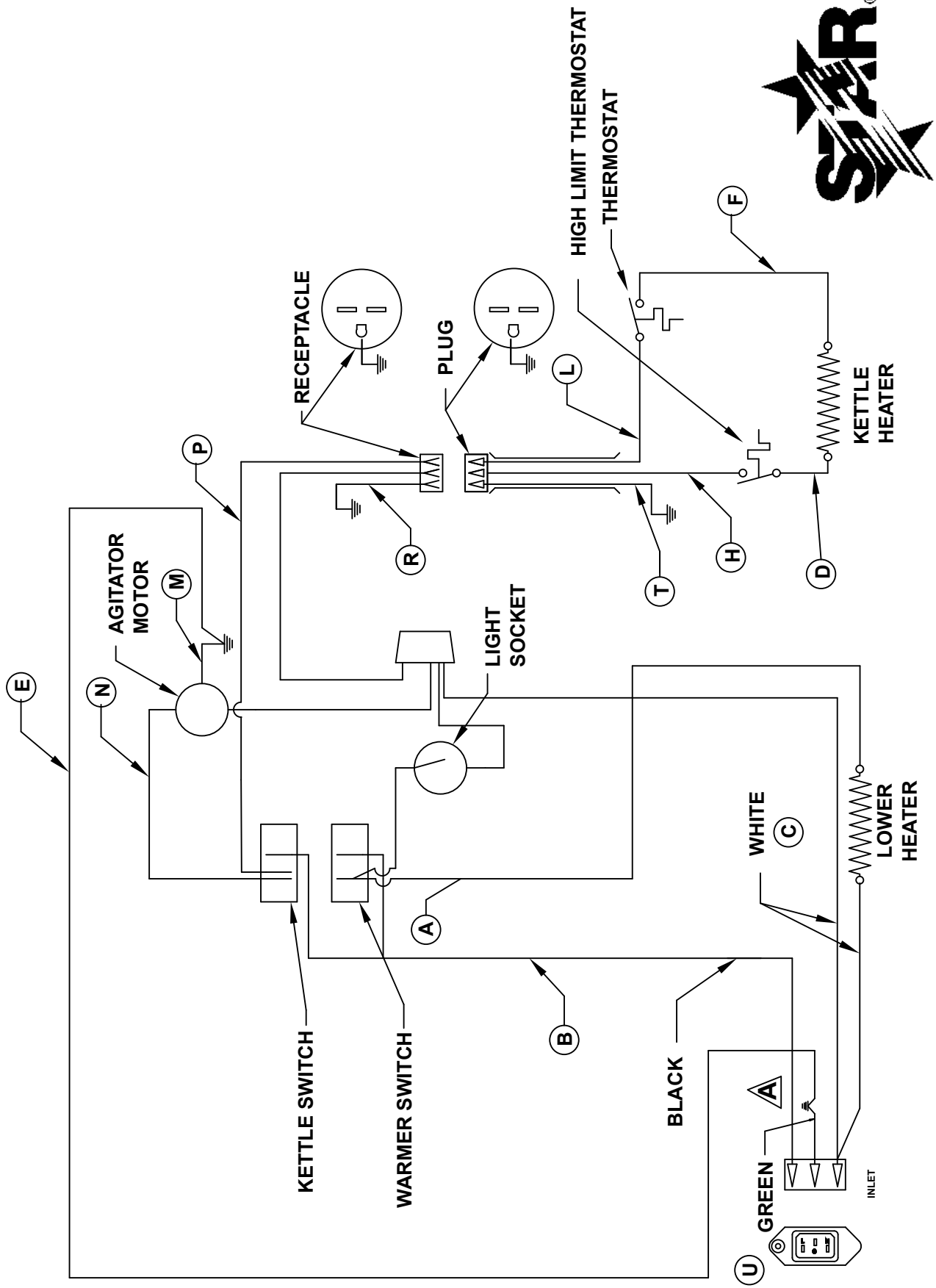

MODEL: WIRE DIAGRAM, 39A, 86S 230CE

THIS DRAWING CONTAINS INFORMATION CONFIDENTIAL TO STAR MFG. INT'L. INC.
 NO REPRODUCTION OR DISCLOSURE OF ITS CONTENTS IS PERMITTED.

STAR MANUFACTURING INTERNATIONAL INC.

SK1317 Rev B 01/04/1996

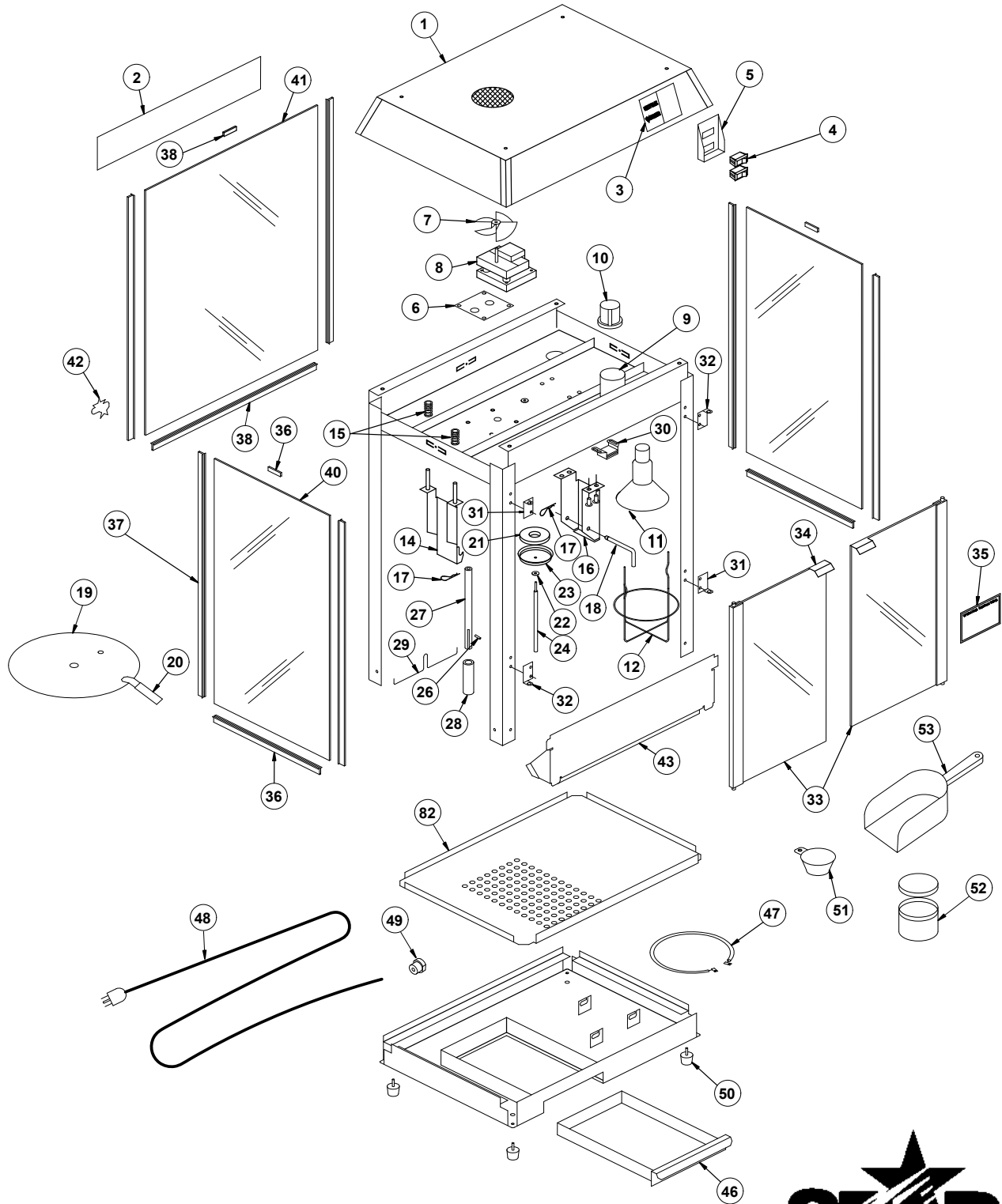

NOTE: SEE DRAWING SK2135 FOR KETTLE ASSY.

SOME ITEMS ARE INCLUDED FOR ILLUSTRATIVE PURPOSES ONLY AND IN CERTAIN INSTANCES MAY NOT BE AVAILABLE



MODEL - 39-A & 86S, 120V/230CE

STAR MANUFACTURING INTERNATIONAL, INC.

SK1359

REV. G

7/22/05

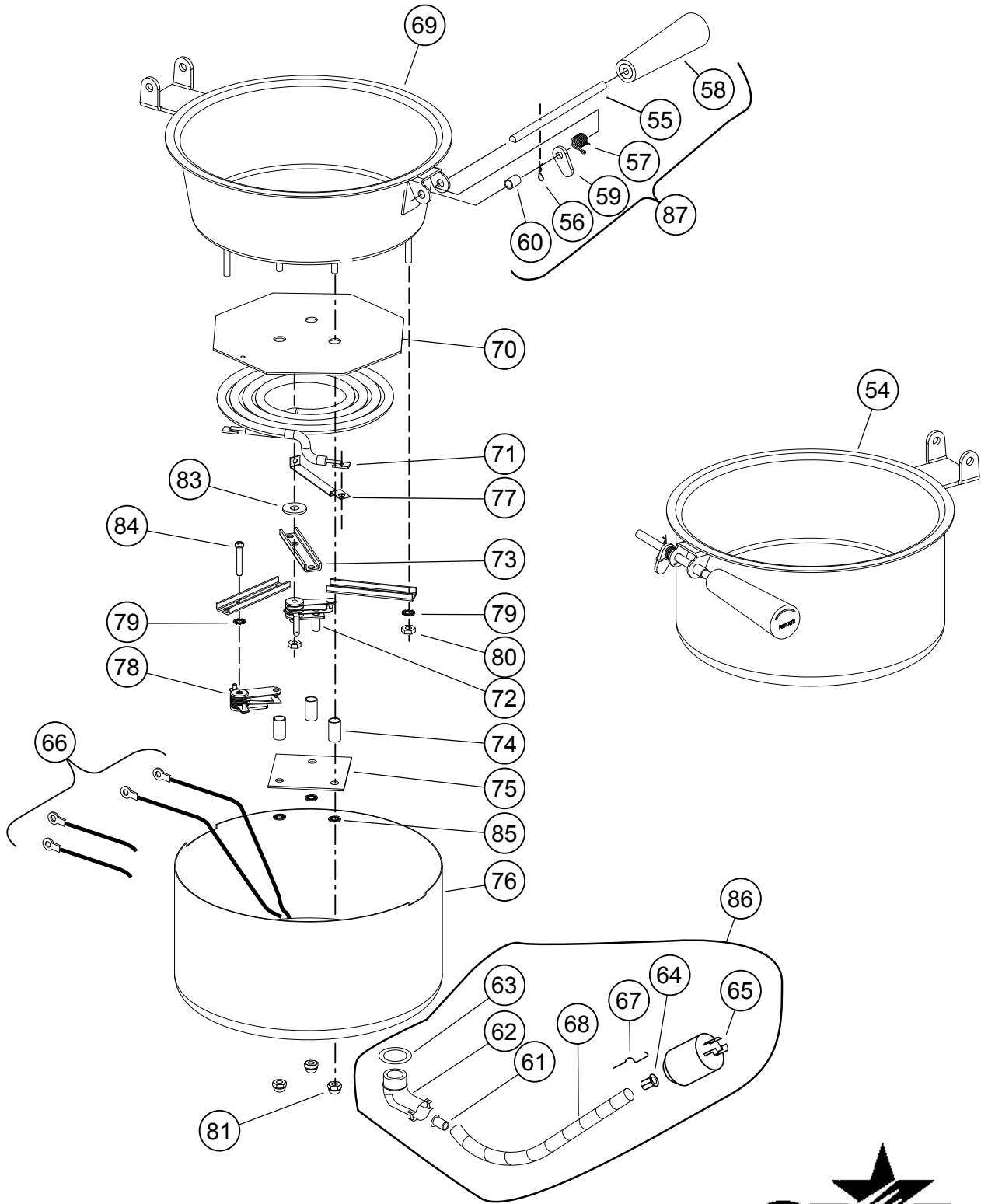

SOME ITEMS ARE INCLUDED FOR ILLUSTRATIVE PURPOSES ONLY AND IN CERTAIN INSTANCES MAY NOT BE AVAILABLE

MODEL - 39-A & 86S, KETTLE ASSY



STAR MANUFACTURING INTERNATIONAL, INC.

SK2135

REV. E

4/22/14

PARTS LIST

February 6, 2013, Rev O

Model: 39A Series 6oz. & 86S Series 8oz. Popcorn Popper				
Fig No	Part No	Qty	Description	Application
1	C3-T1085	1	TOP - YELLOW	39-A
	C3-T1086		TOP - SPOTWELDED, STAINLESS STEEL	39S-A, 39S-AS, 86S, 86SS
	C3-T1087		TOP - WOODGRAIN	39D-A
	C3-T1093		TOP - RED	39R-A
2	2M-Y7447	1	SIGN DISPLAY-OLD STYLE	39D-A
	2M-Y9641	2	SIGN DISPLAY	39S-GWP
	2M-Z0355	1	SIGN DISPLAY	39A, 39S-A, 86S, 86SS
	2M-Y8642	1	SIGN DISPLAY	39R-A
3	2M-Z0090	1	LABEL-SWITCHES	
4	2E-Y6144	3	SWITCH- (3967003 : BELOW)	
	2E-Z0091		SWITCH- (3967004 : ABOVE)	
	2E-Z0091	2	SWITCH - "1"/"0"	
5	C3-Z0265	1	PLATE, SWITCH	
6	2I-Y6709	1	CUSHION-MOTOR	
7	2R-Y4810	1	FAN-BLADE (OLD STYLE, NON-MERKLE-KORFF MOTORS)	
8	PS-39408	1	2U-Y6914, 39&86 RPL. MOTOR KIT	mfg before 6-9-10
	2U-Z12380		MOTOR, GEAR 120V, FAN INCLUDED	mfg after 6-9-10
	PS-39411		2U-Y6926, 39&86 RPL. MOTOR KIT (230CE)	
9	2E-T1042	1	RECEPTACLE T/L (120V)	
	2E-Z0089		RECEPTACLE, STRAIGHT BLADE (230CE)	
10	2E-Y5921	1	LAMP SOCKET (120V)	120V
	2E-Y9433		LAMP SOCKET (230CE)	230CE
11	2S-Y4584	1	LAMP (120V ONLY) 75W	120V
	2S-Y8091		LAMP (230CE ONLY)	230CE
12	2B-Y7619	1	SHIELD-LAMP	
14	2D-4P1004	1	KETTLE LATCH ASSEMBLY	
15	2P-Y6918	2	SPRING LATCH	
16	2V-Y7486	1	BRACKET KETTLE	
17	2A-Y6694	2	CLIP-SHAFT	
18	2A-Y4595	1	KETTLE HINGE PIN	
19	C3-39214	1	KETTLE COVER ASSEMBLY	
20	2R-Y7571	1	COVER TAB	
21	2R-Y7229	1	MAGNET	
22	2A-Y7460	1	SPACER-MAGNET CUP	
23	C3-Y7230	1	CUP-MAGNET	
24	2A-Z4466	1	GUIDE ROD-COVER	
26	2C-T1008	1	GROOVE PIN	
27	2A-Y6919	1	SHAFT 6 11/16"	
28	2A-Y6916	1	COLLAR-AGITATOR (2-1/2")	
29	2B-Y6206	1	BLADE-AGITATOR (6-1/2")	
30	2C-9788	1	MAGNET CATCH	
31	C3-Y7446	2	BRACKET HINGE RIGHT	ALL EXCEPT 39D-A
	C3-Y7459			39D-A

PARTS LIST

April 28, 2011, Rev O

Model: 39A Series 6oz. & 86S Series 8oz. Popcorn Popper				
Fig No	Part No	Qty	Description	Application
32	C3-Y7377	2	BRACKET HINGE LEFT	ALL EXCEPT 39D-A
	C3-Y7458			39D-A
33	C3-39207	2	DOOR AND HINGE ASSEMBLY	39R-A
	C3-39211			39A, 39S-A, 39S-GWP, 86S
	C3-39401			39D-A
	C3-39245	1	DOOR & HINGE ASSY - SELF SERVE RIGHT	86SS
	C3-39238	1	DOOR & HINGE ASSY - SELF SERVE LEFT	86SS
34	C3-Y7475	2	PULL DOOR	
35	2M-Y1755	1	SIGN-OPERATING INSTRUCTIONS	
36	2I-Y7393	4	CHANNEL GLASS (SIDE-TOP & BOTTOM)	39D-A
	2I-Y7442			ALL EXCEPT 39D-A
37	2I-Y7394	6	CHANNEL GLASS (UPRIGHT)	39D-A
	2I-Y7443			39R-A, 39A, 39S-A,
	2I-Z0160			86S, 86SS
38	2I-Y7395	2	CHANNEL GLASS (FRONT-TOP & BOTTOM)	39D-A
	2I-Y7444			ALL EXCEPT 39D-A
39	C3-8260	3	RETAINER-GLASS	
40	2Q-Y7372	2	GLASS-SIDE (1/8" x 11-5/8" x 20-3/8")	39S-A, 39A, 39R-A, 39D-A
	2Q-Z0161		GLASS-SIDE (1/8" x 11-3/8" x 25-3/8")	86S, 86SS
41	2Q-Y7373	1	GLASS-FRONT (1/8" x 17-3/8" x 20-3/8")	39S-A, 39A, 39R-A, 39D-A
	2Q-Z0162		GLASS-FRONT (1/8" x 17-3/8" x 25-3/8")	86S, 86SS
42	2M-Y7480	1	LABEL-STAR EMBLEM	
43	C3-Y8218	1	LOWER DOOR (3966461:BELOW)	39S-A, 39A, 39R-A, 39D-A
	ALSO NEED			
	C3-39222	1	ASSY POST FILLER RIGHT SIDE	
	C3-39223	1	ASSY POST FILLER LEFT SIDE	
	C3-Y8218	1	LOWER DOOR (3966462:ABOVE)	39S-A, 39A, 39R-A, 39D-A
	C3-Z0171	1	LOWER DOOR	86S, 86SS
46	C3-Y7483	1	CORN DRAWER	
47	2N-Y4306	1	ELEMENT (120V ONLY) 50W	
	2N-Y8077		ELEMENT (230CE ONLY)	
48	C3-39111	1	LEAD IN CORD 120V	
	2E-Z0512		LEAD IN CORD 230CE	
49	2K-Y2967	1	BUSHING HEYCO 120V	
	2E-Y9227		INLET 240VE	
50	2I-H7685	4	BUMPER	
51	2L-Y4639	1	CUP-MEASURE 1/4 CUP OIL (not included in all models)	
52	2L-Y4640	1	CUP-MEASURE 3/4 CUP CORN (not included in all models)	
53	2L-Y4916	1	SCOOP-CORN	
54-79, 82-85	C3-39209	1	KETTLE ASSEMBLY COMPLETE 120V	7 LBS SHIPPING
	C3-39219		KETTLE ASSEMBLY COMPLETE 240V	7 LBS SHIPPING
	C3-39235		KETTLE ASSEMBLY COMPLETE 230CE	7 LBS SHIPPING
55	2A-Z4525	1	ROD-HANDLE	

PARTS LIST

February 6, 2013, Rev O

Model: 39A Series 6oz. & 86S Series 8oz. Popcorn Popper				
Fig No	Part No	Qty	Description	Application
56	2B-Y6139	1	CLIP-HANDLE	
57	2P-Y6141	1	SPRING-HANDLE	
58	2R-Y7381	1	HANDLE-KETTLE	
59	C3-Y5378	1	CAM	
60	2A-Y6142	1	SLEEVE-HANDLE	
61	2A-Y6627	1	BUSHING	
62	2E-1177	1	CONNECTOR	
63	2E-Y4967	1	WASHER	
64	2K-1057	1	BUSHING ANTI-SHORT	
65	2P-8354	1	CAP T/L 120V	
	2P-Z0017		PLUG, STRAIGHT BLADE 230CE	
66	2E-Z4458	1	WIRE KIT KETTLE ASSEMBLY (120V)	
	2E-Z4461		WIRE KIT KETTLE ASSEMBLY (230CE)	
67	C3-Y3045	1	GROUND STRAP (120V)	
	C3-39234		WIRE ASSEMBLY - GROUND (230CE)	
68	C3-Y6634	1	CONDUIT	
69	C3-39208-PS	1	KETTLE ASSEMBLY-LINER	
70	C3-39179	1	PLATE HEAT SINK ASSEMBLY	
71	2N-Y7413	1	ELEMENT 1000W 120V	14.41 ohms
	2N-Y7414	1	ELEMENT 1000W 230CE	
72	2T-Y7422	1	THERMOSTAT 120V	
	2T-Y9453	1	THERMOSTAT 230CE	
73	C3-Y7361	3	CHANNEL-HOLDER ELEMENT	
74	C3-Y7482	3	SPACER	
75	2H-Y7693	1	INSULATION PAD	
76	C3-Y7360	1	KETTLE SHELL	
77	C3-Y7362	1	LUG (120V)	
78	PS-G1499	1	HIGH LIMIT PARTS KIT., 39/86	
	2T-Z10182		RESETTABLE THERMOSTAT HIGH LIMIT 120V,	mfg. after 9/2007
79	2C-1827	6	WASHER #10 EXT STL	
80	2C-2560	6	NUT 10-24 HEX STL	
81	2C-2559	3	ACORN NUTS 10-24	
82	C3-Y7386	1	PAN - CORN	
83	2C-6334	1	WASHER #16 FL BR NP	
84	2C-H1559	1	SCREW 8-32 X 1.25 ST RH NP	
85	2C-6260	3	WASHER #10 INT STL NP	
86	PS-39217	1	KETTLE CONDUIT COMPLETE (120V)	
87	PS-39216	1	KETTLE HANDLE ASSEMBLY COMPLETE	

STAR INTERNATIONAL HOLDINGS INC. COMPANY

Star - Holman - Lang - Wells - Bloomfield - Toastmaster

10 Sunnen Drive, St. Louis, MO 63143 U.S.A.

(314) 678-6303

www.star-mfg.com