

MODEL
IRCS2-SBW, IRCS2-NW
Conveyor Toasters

Electronic Controls

Conveyor Toasters Installation Instructions



These symbols are intended to alert the user to the presence of important operating and maintenance instructions in the manual accompanying the appliance.

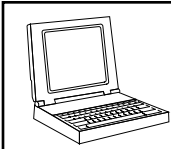

Go to:
www.star-mfg.com/scripts/manuals.aspx
to obtain this units installation & operations manual, warranty & other documents.

NOTICE

Using any part other than genuine Holman factory supplied parts relieves the manufacturer of all liability.

Holman reserves the right to change specifications and product design without notice. Such revisions do not entitle the buyer to corresponding changes, improvements, additions or replacements for previously purchased equipment.

Due to periodic changes in designs, methods, procedures, policies and regulations, the specifications contained in this sheet are subject to change without notice. While Holman Manufacturing exercises good faith efforts to provide information that is accurate, we are not responsible for errors or omissions in information provided or conclusions reached as a result of using the specifications. By using the information provided, the user assumes all risks in connection with such use.



CAUTION GENERAL SAFETY INFORMATION

This equipment is designed and sold for commercial use only by personnel trained and experienced in its operation and is not sold for consumer use in and around the home nor for use directly by the general public in food service locations.

Before using your new equipment, read and understand all the instructions & labels associated with the unit prior to putting it into operation. Make sure all people associated with its use understand the units operation & safety before they use the unit.

All shipping containers should be checked for freight damage both visible and concealed. This unit has been tested and carefully packaged to insure delivery of your unit in perfect condition. If equipment is received in damaged condition, either apparent or concealed, a claim must be made with the delivering carrier.

Concealed damage or loss - if damage or loss is not apparent until after equipment is unpacked, a request for inspection of concealed damage must be made with carrier within 15 days. Be certain to retain all contents plus external and internal packaging materials for inspection. The carrier will make an inspection and will supply necessary claim forms.

GENERAL INSTALLATION INFORMATION

The unit was shipped fully assembled and ready to plug into a standard outlet specified for its voltage and amp draw. If improper electrical supply is determined, contact a qualified electrician prior to using the unit. Removal and replacement of the power cord and plug will void the warranty. For assistance, contact your local authorized service agent for service or required maintenance.

Level unit using the adjustable feet under the unit (approximately 1/2" adjustment).

Before using the unit for the first time, wipe down the exterior with a damp cloth.

Allow enough space around the toaster for adequate ventilation. Do not operate the unit without the crumb tray properly positioned. Overheating and poor toasting may occur. Read all labels on the unit and follow their instructions.

MAINTENANCE AND REPAIRS

Contact the factory, a service representative or a local service company for service or required maintenance. Go to www.star-mfg.com/scripts/manuals.aspx to find a service agent near you. Replacement cord sets must be purchased from Star Manufacturing International, Inc. or our authorized agents.

Should you need any assistance regarding the operation or maintenance of any Holman equipment; write, phone, fax or e-mail our service department. In all correspondence mention the model number and the serial number of your unit, along with the voltage.

Business Hours: 8 am to 4:30 p.m. Central Standard Time

Telephone: (877) 242-0270

Fax: (314) 781-2714

E-mail: Parts@star-mfg.com
Service@star-mfg.com
Warranty@star-mfg.com

Website: www.star-mfg.com

Mailing Address: Star International Holdings Inc., Company
10 Sunnen Drive
St. Louis, MO 63143
U.S.A.

ELECTRICAL CONNECTION

Before making any electrical connection to this unit, check that the power supply is adequate for the voltage, amperage and requirements stated on the rating plate. A wiring diagram is included in the Installation & Operations manual, which can be downloaded at www.star-mfg.com/scripts/manuals.aspx.

Disconnect the unit from the power source before installing or removing any parts.

Be absolutely sure that the ground connection for the receptacle is properly wired. Do not connect equipment to power without proper ground connections. Improper grounding may result in personal injury or fatality.

 **WARNING** DO NOT CUT OR REMOVE THIS PLUG OR GROUNDING PRONG FROM THE PLUG.

 **WARNING** CONNECT/PLUG UNIT INTO DEDICATED A.C. LINE ONLY SPECIFIED ON THE DATA PLATE OF THE UNIT.

 **CAUTION** CERTAIN SURFACES ARE EXTREMELY HOT DURING OPERATION AND CARE SHOULD BE TAKEN WHILE USING THIS UNIT.

 **WARNING** DO NOT IMMERSE OR LET THE UNIT STAND IN WATER.

 **WARNING** DO NOT HOSE DOWN THE UNIT OR THE TABLE/COUNTER IF THE UNIT IS ON THE TABLE/COUNTER.

 **WARNING** KEEP AWAY FROM RUNNING WATER.

IRCS2-SBW INSTALLATION REQUIREMENTS

1. Space: 16"x24"x18"
(width x depth x height)
2. Electricity: 208/240 Volts, 30 Amps, NEMA 6-30R Receptacle

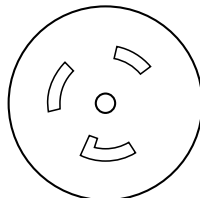

NEMA L6-30R

IRCS2-NW INSTALLATION REQUIREMENTS

1. Space: 10" x 29" x 17.5"
(width x depth x height)
2. Electricity: 208/240 Volts, 12 Amps, NEMA 6-20R Receptacle

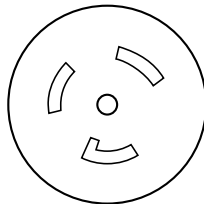

NEMA L6-20R

NOTE: Ensure to clean the toaster properly before using it for the first time. Refer to the Cleaning Procedure document for cleaning instructions.

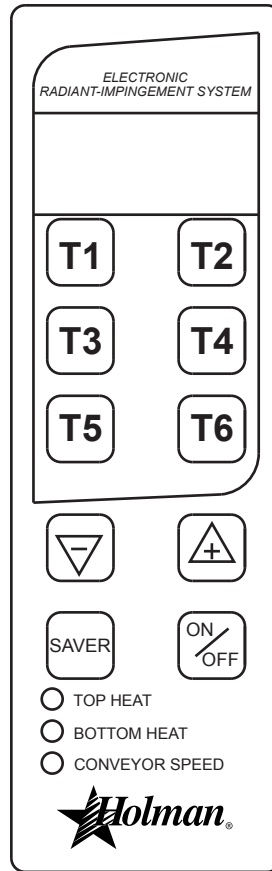

IL2711

The Holman IRCS conveyor toaster comes with pre-programmed factory default settings for ALL MENU BUTTONS.

Factory default settings are as follow:

IRCS2-SBW DEFAULT SETTINGS			
Menu Buttons	Top Heat	Bottom Heat	Conveyor Speed
T1	3.2	4.3	1
T2			
T3			
T4			
T5			
T6			

IRCS2-NW DEFAULT SETTINGS			
Menu Buttons	Top Heat	Bottom Heat	Conveyor Speed
T1	4.0	5.4	1
T2			
T3			
T4			
T5			
T6			

POWER SAVER SWITCH

There are three Power Saver modes:

- ON:** Unit is in pre-programmed power saving setting.
- OFF:** Power Saver mode is turned off.
- AUTO ON:** Power Saver turns on when there has been no activity for a programmed length of time.

The operator may adjust the level of power reduction for the saver mode. (Note: conveyor may move slowly when in saver mode.)

Two buttons (+) and (-) are used when increasing or decreasing the value of each programmable setting.

A red LED light located at the lower portion of the control panel label will indicate if the value for top heat, bottom heat or conveyor speed is being adjusted.



CERTAIN SURFACES ARE EXTREMELY HOT DURING OPERATION AND CARE SHOULD BE TAKEN WHILE USING THIS UNIT.

START UP

When the toaster has been plugged into a suitable outlet and power supply, the word **OFF** will be displayed on the L.E.D. read out.

- A. Press the **ON/OFF** button once to turn on the toaster. The toaster will now enter into pre-heat and “PREHT” will be displayed (the elements will begin to glow but the conveyor and fan motor will not turn on).
- B. After one minute, the fan motor will turn on and the conveyor will begin turning at the previously saved setting (for initial start up, the drive motor will operate at the factory default setting).
- C. After 14 minutes, the display will show the last used program selection i.e. (for initial startup, CROIS, MUFFIN, will be the last program selected).

DAILY OPERATION

Check the power cord to insure that it is plugged into a proper outlet.

Press the **ON/OFF** button once to turn the toaster on. Press the button a second time to turn the toaster off.

NOTE: When the toaster is turned off, the fan and conveyor motors will continue to run for five minutes. The words **COOL** and **DOWN** will be alternately displayed during that time. After five minutes, the word **OFF** will be displayed until the **ON/OFF** button is pressed again.

Once the toaster has been pre-heated, the menu buttons can be pressed to change to **T1, T2, T3, T4, T5, T6**

OPERATING HINTS AND SAFETY

IMPORTANT: If “HIGH TEMP” shows on the display

1. Turn off the toaster and allow it to fully cool down.
2. Inspect the fan inlet on the bottom of the toaster and remove anything blocking the cooling fan inlet.
3. Press the red high temperature limit reset button on the back of the toaster. (*Note: There is one reset on each side.*) (*Note: the toaster must be fully cool in order for the limit switch to reset.*)
4. Turn on the toaster and check for proper operation.
5. If cleaning the cooling fan inlet does not correct the problem, contact the factory or an authorized service agency for required maintenance.

Disconnect power to the unit with the **ON/OFF** button at the end of each day of operation.

Do not leave the unit in operation without an attendant.

Do not leave the unit at high temperature when not in use or during idle periods. This will cause food particles and grease film to carbonize.

The cooling fan will continue to run until the toaster has completely cooled. If the toaster **MUST** be moved after using, allow the cooling fan to turn **OFF** before unplugging.

PROGRAMMING

A. CONVEYOR SPEED (temporary setting)

The conveyor speed is programmable with a range from 1 to 99 with 1 being the slowest and 99 being the fastest. Each menu item can have independent conveyor speed settings.

B. PROGRAMMING VALUES FOR MENU ITEMS

To make a program change to the top & bottom elements, or conveyor speed, you must first be in the menu item you want changed. Example: to change the programmed conveyor speed for croissants, the display must read **CROIS**. To change the programmed conveyor speed for MUFFIN, the display must read **MUFFIN** and so on for each menu item.

- 1) Select the menu item you want to change i.e. **T1, T2, T3, T4, T5 or T6**.
- 2) Press and hold both (+) AND (-) buttons for 3 seconds until the display goes blank, release the buttons and the display will show three characters for the menu item elected and the last two characters for the current value setting, i.e. **T1, T2, T3, T4, T5 or T6**. The red L.E.D. light for upper front element at the bottom of the label will flash.
- 3) Press the (+) or (-) buttons to increase or decrease the setting for the upper element.
- 4) Press the button for the menu button again and the red L.E.D. for the up lower element will flash.
- 5) Press the (+) or (-) buttons to increase or decrease the setting for the lower element.
- 6) Press the button for the menu button again and the red L.E.D. for the conveyor speed will flash.
- 7) Press the (+) or (-) buttons to increase or decrease the setting for the conveyor speed.
- 8) To skip one feature setting with out making any changes, press the menu item button one time and the red L.E.D. light for the next item will now flash.
- 9) To change the POWER SAVER values press the SAVER button or to save your new setting(s), and exit the program mode press the menu button.
- 10) The last two characters in the display will show **MN** for minutes.
- 11) The first three characters will be numerical to represent the time setting.
- 12) When set to “OFF” the Saver button will be disabled during operation. The PowerSaver can be set to “OFF” or using the (+) or (-) set the time from 15 to 480 minutes.
- 13) Press the SAVER button to change the power reduction using the (+) or (-) buttons to increase or decrease the setting.
- 14) Press the POWER SAVER button to save changes and to exit.

CLEANING

Preventive maintenance for your Holman toaster consists of the following recommended cleaning procedures. To keep your toaster in its top operating condition, these steps should be performed on a daily or weekly basis as required.

Supplies

KAY® QSR Oven Cleaner

KAY® QSR Heavy Duty Multi-Purpose Sink Detergent
(dispensed use solution)

KAY® Sink Sanitizer (use solution prepared at the sink)

No Scratch Pad

Red Cloth

Daily Procedure:

1. Turn toaster off, conveyor will continue to run until cooled down (approx. 5-10 minutes)
2. Immediately spray the oven cleaner onto the No Scratch Pad and scrub the conveyor chain while it is still warm and moving.

NOTE: DO NOT SPRAY directly onto the conveyor belt or into the cooking chamber. Overspray onto the heating elements can damage or shorten the life of the elements.

3. Wash the No Scratch pad at the 3 compartment sink and then soak with Multi-Purpose Sink Detergent. Ring the pad out so that it is only damp and continue to scrub the conveyor belt while it's still moving.
4. Rinse the No Scratch pad at the 3 compartment sink to remove all detergent and then soak with clean warm water. Ring the pad out so that it is only damp and continue to scrub the conveyor belt while it still moving.
5. Wipe the conveyor belt with a clean red cloth dampened with sanitizer solution while it is still moving. Allow to air dry.
6. Rinse the No Scratch pad at the 3 compartment sink and then soak with clean warm water. Ring the pad out so that it is only damp and wipe exterior areas of the toaster.
7. Remove interior crumb tray and bottom catch tray and take to the three compartment sink. Spray the pieces with oven cleaner and allow to sit on the drain board for a minimum of five minutes.
8. Wash, Rinse and Sanitize removable pieces and allow to air dry before sliding the trays back into the unit.
9. Unit is now ready to turn ON for warm up and use.



DO NOT IMMERSE THE UNIT IN WATER OR LET THE UNIT STAND IN WATER.



DO NOT USE A NON-STICK SPRAY ON THE CONVEYOR BELT, IT WILL CAUSE A STICKY BUILD-UP AND INCREASE STICKING.



DO NOT HOSE DOWN THE UNIT OR THE TABLE/COUNTER IF THE UNIT IS ON THE TABLE/COUNTER.



KEEP AWAY FROM RUNNING WATER.

OPERATION PROCEDURES

Used to toast croissants and english muffins

To Turn unit ON

1. Ensure toaster is plugged in
2. Press ON/OFF burron on each control panel. Screen will display "PREHT" for 15 minutes. DO NOT toast any product while the screen displays "PREHT"
3. Select the desired menu button.
4. Toast product in corresponding belt.

To Turn unit OFF

1. Ensure there is no product in the toasting chamber
2. Press ON/OFF button on each control panel. Screen will shuffle "COOL" and "DOWN" for 10 minutes.

NOTE: belts will continue to move for the duration of the cool-down time. Use this time to clean the toaster.

ROUTINELY CHECK

Entering Programming Mode

NOTE: Ensure the toaster is ON

NOTE: Changes to the same product must be repeated for each belt.

1. Select product
2. Press and hold up and down arrows at the same time. You will enter programming mode.
3. Use the up and down arrows to select the desired top heat.
4. Press product button on control
5. Use the up and down arrows to select desired bottom heat.
6. Press product button on control
7. Usse the top and down arrows to select desired conveyor speed
8. Press product button on control 2-3 times until you exit programming mode.

NOTE: Changes in belt speed will be made immediately. Changes in top/bottom heat will take time to adjust depending on the specifics of the change

STAR INTERNATIONAL HOLDINGS INC. COMPANY

Star - Holman - Lang - Wells - Bloomfield - Toastmaster

10 Sunnen Drive, St. Louis, MO 63143 U.S.A.

(314) 678-6303

www.star-mfg.com

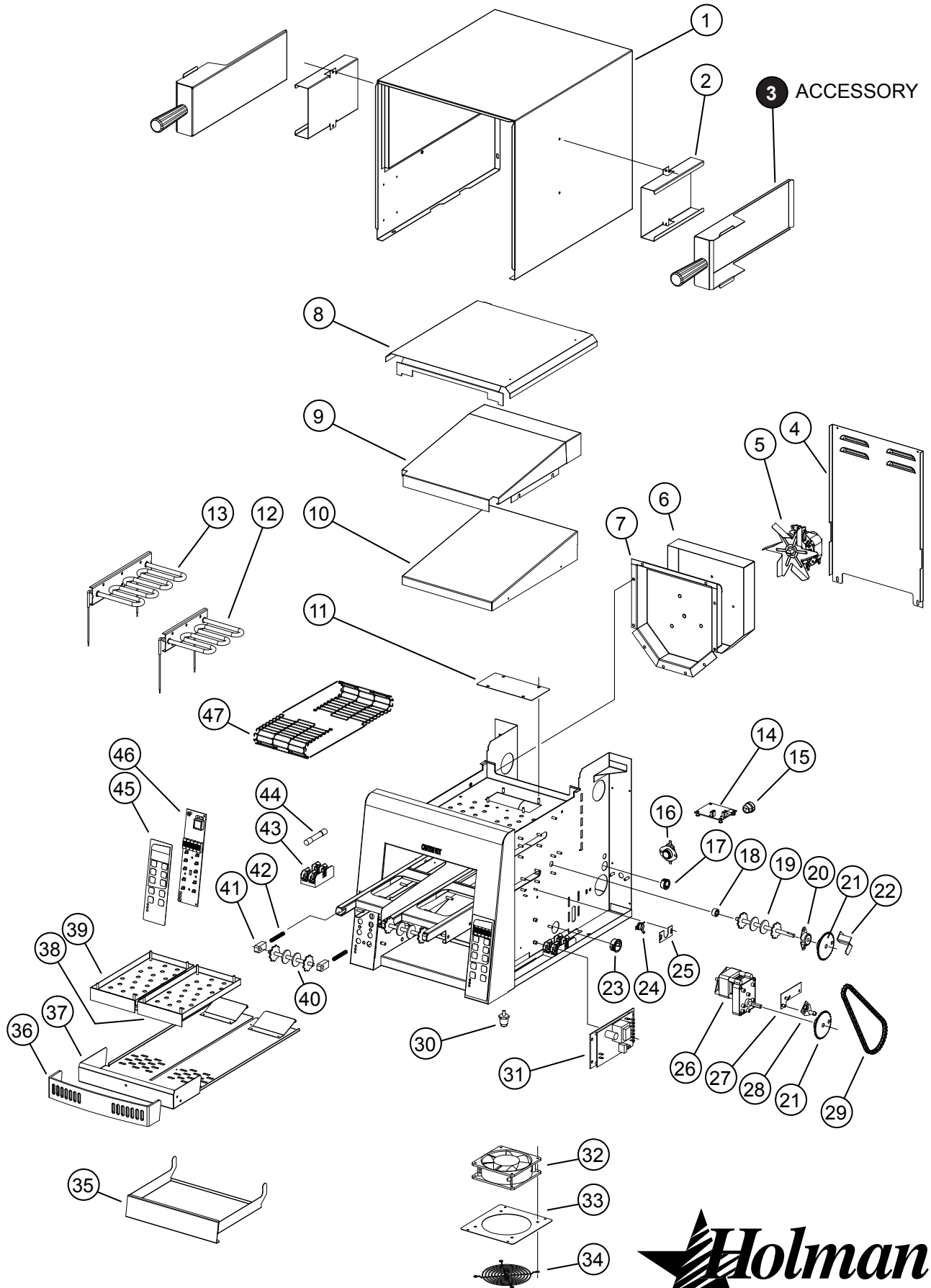

MODEL: IRCS2-SBW:
Split Electronic Conveyor Toaster



SK2776

Rev. - 5/03/14

2M-Z18529: Split Conveyor Toaster, IRCS2-SBW

Model: IRCS2-SBW Split Conveyor Toaster			
Fig No	Part Number	Qty	Description
1	HC-120334	1	BODY WRAP ASSY IRCS-2-SB
2	HC-Z17531	2	PADDLE HOLDER
3	HC-120333	1	PADDLE (ACCESSORY)
4	HC-Z17540	1	BACK PANEL
5	2U-Z17519	1	BLOWER-IMPINGEMENT
6	HC-Z17546	1	COVER-REAR DUCT
7	HC-Z17547	1	REAR PLENUM
8	HC-120341	1	TOP BAFFLE ASSY IRCS2-SB
9	HC-Z17541	1	COVER-TOP INSULATION
10	HC-Z17542	1	PLENUM-IMPINGEMENT
11	HC-Z17544	1	COVER PLATE-BEARING ACCES
12	2N-Z16981	2	ELEMENT,208V,1400W
	2N-Z17528		ELEMENT,240V,1400W
13	2N-Z16982	2	ELEMENT 208V,1000W
	2N-Z17529		ELEMENT, 240V, 100W
14	2E-Z17515	1	USB BOARD
15	2K-Y6764	1	BUSHING - STRAIN RELIEF
16	2E-200566	2	SWITCH, RESET, 0796
17	2K-8043	2	BUSHING HEYCO SB-875-10
18	HC-120342	2	BEARING ASSEMBLY-GRAPHITE
19	2A-Z17509	2	DRIVE SHAFT
20	HA-112263	2	BEARING ASSY PTFE/BRONZE
21	2P-200648	4	SPROCKET, 25B32 X 5/16
22	HC-Z18527	2	BRACKET CONV SHAFT
23	2K-Z6183	2	BUSHING 1.125
24	2E-200574	1	SWITCH,FAN, CERAMIC,
25	HG-402144	1	FAN SWITCH BRACKET (-T)
26	2U-Z9657	1	DRIVE MOTOR, RIGHT
	2U-Z9658		DRIVE MOTOR, LEFT
27	HC-Z17468-1	1	BRACKET-SPEED SENSOR LT
	HC-Z17468-2		BRACKET-SPEED SENSOR RT
28	2E-Z17514	2	SPEED SENSOR
29	2P-Z18528	2	CHAIN
30	2R-200709	4	LEG 1 INCH CHROME PLASTIC
31	2E-Z17513	2	POWER BOARD
32	2U-Z17520	1	MUFFIN FAN 130CFM
33	HC-Z17511	1	PLATE-FAN MOUNT
34	2R-200562	1	FAN GUARD
35	HC-120336	1	PULL OUT TRAY ASSY IRCS-2
36	2R-200787	1	QCS 1&2 CRUMB TRAY GUARD
37	HC-120335	1	CRUMB TRAY ASSY IRCS-2-SB
38	HC-120338	1	RT IMPINGEMENT PANEL ASSY
39	HC-120339	1	LEFT IMPINGEMENT PANEL
40	2A-Z16807	2	IDLER ASSEMBLY R2N

Model: IRCS2-SBW Split Conveyor Toaster			
Fig No	Part Number	Qty	Description
41	2P-200700	4	BEARING-PTFE SPRING LOAD
42	2P-200736	4	2 INCH BEARING SPRING
43	2E-Z5681	2	FUSEHOLDER, CLASS G
44	2E-200596	4	15 AMP FUSE, TYPE G
45	2M-Z17510	2	LABEL-CONTROL PANEL
46	HC-Z18355	2	CONTROL BOARD
47	2B-Z16768	86	BELTING 4.75W 27x0.050
NI	2E-Z17441	1	CORDSET L6-30P 12/3 84IN
NI	2E-Z17516	2	USB CABLE

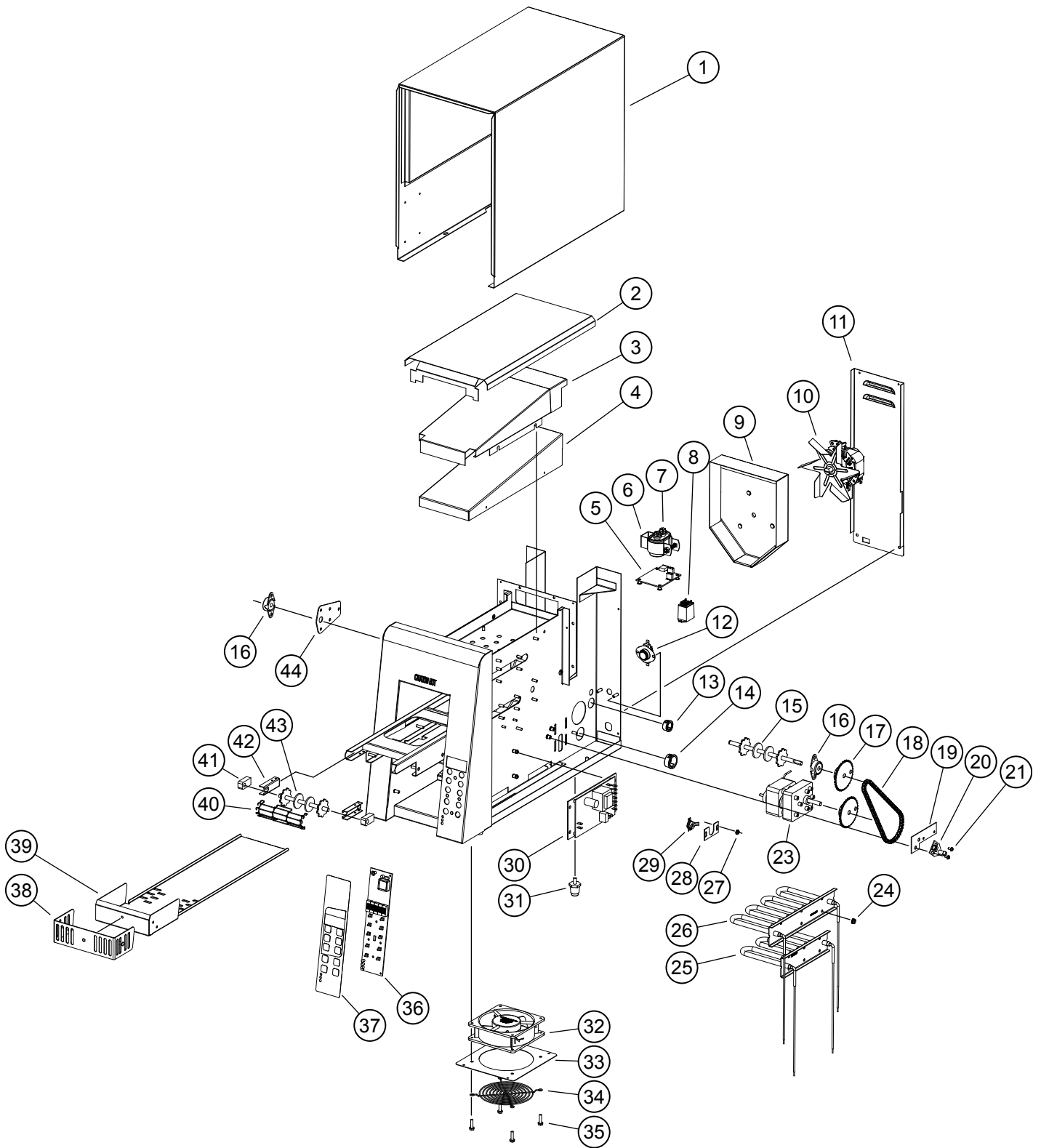

MODEL: IRCS2-NW:
Impingement Electronic Conveyor Toaster

Model: IRCS2-NW Impingment Conveyor Toaster

Fig No.	Part Number	Qty	Description	Application
1	HC-120356	1	ENCLOSURE ASSEMBLY	
2	HC-120358	1	BAFFLE-AIR FLOW	
3	HC-Z18634	1	PLENUM	
4	HC-Z18633	1	PLENUM TOP	
5	2E-Z17515	1	USB BOARD	
6	2E-Z17786	1	CONDUIT CLAMP 1 1/2	
7	2E-Z17522	1	CAPACITOR	
8	2E-Z4358	1	RELAY 230V	
9	HC-120355	1	FAN DUCT ASSY.	
10	2U-Z17519	1	BLOWER-IMPINGEMENT	
11	HC-Z18636	1	BACK PANEL IRCS2-ND	
12	2E-200566	1	SWITCH, RESET, 0796	
13	2K-8043	1	BUSHING HEYCO SB-875-10	
14	2K-Z6183	1	BUSHING 1.125	
15	2A-Z16808	1	DRIVE ASSEMBLY R2N	
16	HA-112261	2	BEARING ASSY, 5/16 TEFLON	
17	2P-200648	2	SPROCKET, 25B32 X 5/16	
18	2P-Z18950	1	CHAIN #25 92 LINKS 23"	
19	HC-Z17468-2	1	BRACKET-SPEED SENSOR RT	
20	2E-Z17514	1	SPEED SENSOR	
21	2C-200004	16	SCREW 6-32X5/16 THP SS	
23	2U-Z9657	1	MOTOR AC 11 RPM CW	
24	2C-08-07-0207	26	NUT 10-24 HEX STL NP	
25	2N-Z16982	1	ELEMENT 208V,1000W	208V
	2N-Z17529		ELEMENT 240V 1000W	240V
26	2N-Z16981	1	ELEMENT 208V,1400W	208V
	2N-Z17528		ELEMENT 240V, 1400W	240V
27	2C-Z2594	2	NUT 6-32 HEX W STL NP	
28	HG-402144	1	FAN SWITCH BRACKET (-T)	
29	2E-200574	1	SWITCH,FAN, CERAMIC,	
30	2E-Z17513	1	POWER BOARD, IRCS W/REV	
31	2R-200709	4	LEG 1 INCH CHROME PLASTC	
32	2U-200577	1	MOTOR, FAN 240V, HI-OUTPU	
33	HC-Z17511	1	PLATE-FAN MOUNT	
34	2R-200562	1	FAN GUARD	
35	2C-08-07-0117	4	SCREW 10-24X3/4 FZA	
36	HC-Z18954	1	CONTROL PRGM IRCS2-NW	
37	2M-201813	1	LABEL, QCSE	
38	HC-Z16937	1	BURN GUARD FAB'D R2N	
39	HC-Z18637	1	RACK, TOAST SLIDE	
40	PS-Z16768-43	1	COMPLETE BELT ASSY IRCS2	
41	2P-200700	2	BEARING-PTFE SPRING LOAD	
43	2A-Z16807	1	IDLER ASSEMBLY R2N	

Model: IRCS2-NW Impingment Conveyor Toaster

Fig No.	Part Number	Qty	Description	Application
43	HA-Z9743	2	SPRING RETAINER (2)	
44	HC-Z16924	1	SHAFT ACCESS COVER PLATE	
NI	2M-Z18721	1	LABEL - WIRING	
NI	2K-Y3240	1	BUSHING, STRAIN RELIEF	
NI	2E-Z18952	1	CORD SET L6-20 14/3 6FT	
NI	2B-Z18956	1	LOAD UP 5" EURO WIRE	

WIRING DIAGRAM IRCS2-SBW

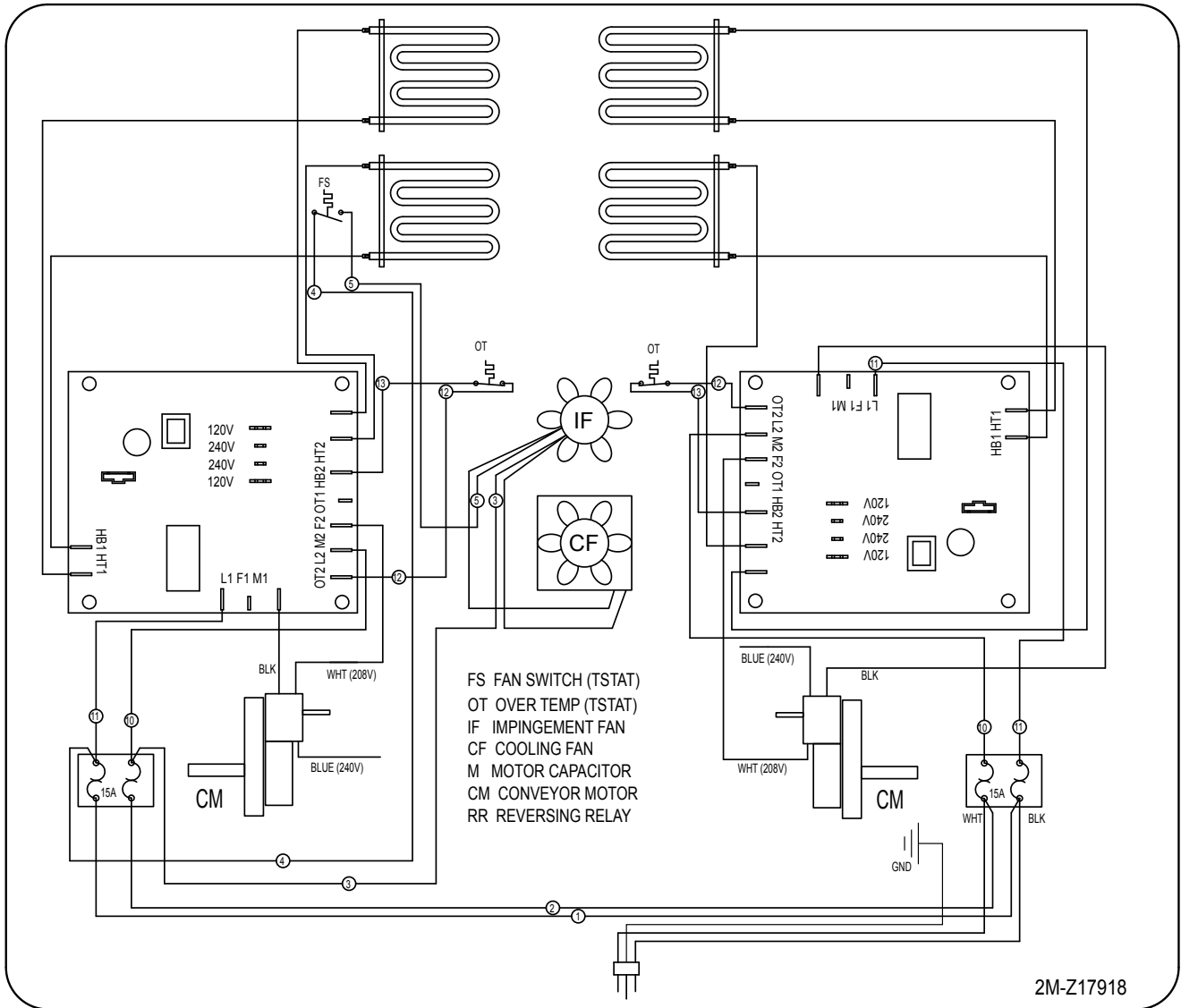

2M-Z17918

WIRING DIAGRAM IRCS2-NW

