



Contact Toaster

Owner's Manual

Models

SCT4000E, and SCT4000E-RR

This manual includes material related to installation, use, cleaning, and care. Exploded view[s], as well as any available parts list[s] and wiring diagrams pertaining to the unit covered by this manual are also included.

This manual must be read and understood by all persons using or installing this appliance. Contact your Star dealer if you have any questions concerning installation, use, or maintenance of this equipment.

DO NOT DISCARD THIS MANUAL.



SCT4000E

LIMITED EQUIPMENT WARRANTY

Star Manufacturing [as well as its subsidiaries, Toastmaster and Holman] warranties new products to be free from defects in material and/or workmanship for a period of one [1] year from the date of original installation, except as noted below. Defects that occur as a result of normal use, within the time period and limitations defined in this warranty, will at Star's discretion have the parts replaced or repaired by Star or a Star-authorized service agency.

THIS WARRANTY IS SUBJECT TO ALL LISTED CONDITIONS.

Repairs performed under this warranty are to be performed by a Star authorized service agency. Star will not be responsible for charges incurred or service performed by non-authorized repair agencies. In all cases, the nearest Star-authorized service agency must be used. Star will be responsible for normal labor charges incurred in the repair or replacement of a warranted product within 50 miles (80.5 km) of an authorized service agency. Time and expense charges for anything beyond that distance will be the responsibility of the owner. All labor will need to be performed during regular service hours. Any overtime premium will be charged to the owner. For all shipments outside the U.S.A. and Canada, please see the International Warranty for specific details. It is the responsibility of the owner to inspect and report any shipping damage claims, hidden or otherwise, promptly following delivery. No mileage or travel charges will be honored on any equipment that is deemed portable. In general, equipment with a cord and plug weighing less than 50 lb. (22.7 kg) is considered portable and should be taken or shipped to the closest authorized service agency, transportation prepaid.

PORTABLE EQUIPMENT EXAMPLES

- 514LL fryer
- 15MC and 18MCP hot food merchandisers
- QCS1, QCS2, and RCS2 toasters
- 16PD-A pretzel merchandisers
- Condiment dispensers except HPD- and SPD-series models
- All pop-up toasters
- All pastry display cabinets
- All heat lamps
- J4R popcorn machine
- 12NCPW and 15NCPW nacho merchandisers
- Nacho cheese warmers except 11WLA-series models
- Specialty food warmers except 13OR, 11RW, and 11WSA models
- All butter dispensers
- All nacho chip merchandisers
- All accessories

CONTACT

Should you require any assistance regarding the operation or maintenance of any Star equipment; write, phone, fax or email our service department. In all correspondence mention the model number and serial number of your unit, as well as the voltage or type of gas you are using.

Business hours are 8:00 a.m. to 4:30 p.m. Central Standard Time (CST)

Telephone: (800)-264-7827

Fax: (314)-781-2714

Email: Customerservice@star-mfg.com

www.star-mfg.com

WARRANTY EXCLUSIONS

THE FOLLOWING WILL NOT BE COVERED UNDER WARRANTY.

- Any product which has not been used, cleaned, maintained, or installed in accordance with the directions published in the appropriate installation sheet and/or owner's manual as well as national and local codes, including incorrect gas, electrical, or water connection. Star is not liable for any unit which has been mishandled, abused, misapplied, subjected to chlorides, harsh chemicals, or caustic cleaners, damaged from exposure to hard water, modified by unauthorized personnel, damaged by flood, fire, or other acts of nature [or God], or which have an altered or missing serial number.
- Installation, labor, and job checkouts, calibration of heat controls, air and gas burner/bypass/pilot adjustments, gas or electrical system checks, voltage and phase conversions, cleaning of equipment, or seasoning of griddle surface.
- Replacement of fuses or resetting of circuit breakers, safety controls, or reset buttons.
- Replacement of broken or damaged glass components, quartz heating elements, and light bulbs.
- Labor charges for all removable parts in gas charbroilers and hotplates, including but not limited to burners, grates, and radiants.
- Any labor charges incurred by delays, waiting time, or operating restrictions that hinder a service technician's ability to perform service.
- Replacement of items subject to normal wear or items that can easily be replaced during a daily cleaning routine, such as but not limited to knobs, bulbs, fuses, quartz heating elements, baskets, racks, and grease drawers.
- Components that should be replaced when damaged or worn, but have been field-repaired instead [eg. field-welded fry pots]
- Any loss of business or profits.

PRODUCTS	PARTS	LABOR
Star-Ultra Max® fryers, griddles, charbroilers, and hotplates	2 years	2 years
Star-Max® fryers, griddles, charbroilers, and hotplates	2 years	2 years
Jetstar® popcorn poppers	2 years	2 years
Staltek™ roller grill coatings	5 years	
Cast iron grates, burners; and burner shields	180 days	
Star, Toastmaster, or Holman parts sold to repair equipment	90 days	
Service First	1 year	

TABLE OF CONTENTS

Warranty	i
Receiving and Service Information	iii
General Information and Installation	1
Conveyor Access and Removal	2
Bun Thickness Adjustment	3
PTFE Sheet Replacement	3
Daily Operation	4
Cleaning	5
Additional Electronic Settings	6-7
Control Label Replacement	8
Exploded Views	8
Parts List	9-10
Wiring Diagrams	11
Specifications	12
Troubleshooting	13

SAFETY SYMBOLS

These symbols are intended to alert the user to the presence of important operating and maintenance instructions in the manual accompanying the appliance.

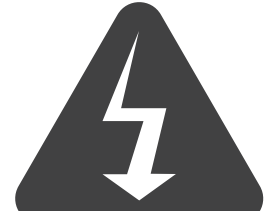

THOROUGHLY INSPECT YOUR UNIT ON ARRIVAL

This unit has been tested for proper operation before leaving our plant to ensure delivery of your unit in perfect condition. However, there are instances in which the unit may be damaged in transit. In the event you discover any type of damage to your product upon receipt, you must immediately contact the transportation company who delivered the item to you and initiate your claim with that company. If this procedure is not followed, it may affect the warranty status of the unit. If damage or loss is not apparent until after equipment is unpacked, a request for inspection of concealed damage must be made with carrier within 15 days. Please record the model number, serial number, voltage, and purchase date in the area below at the time of receipt..

Model Number _____

Serial Number _____

Voltage _____

Purchase Date _____

MAINTENANCE AND REPAIRS

Contact your local authorized service agent for service or required maintenance. Please have the information in the above fields ready when you call to ensure a faster service.

Using any part other than genuine Star factory supplied parts relieves the manufacturer of all liability. Due to periodic changes in designs, methods, procedures, policies, and regulations, the specifications contained in this document are subject to change without notice. Star reserves the right to change product specifications and design without notice. In regards to previously purchased equipment, such revisions do not entitle the buyer to corresponding changes, improvements, additions or replacements. While Star International Holdings Inc. exercises good faith efforts to provide information that is accurate, we are not responsible for errors or omissions in information provided or conclusions reached as a result of using the specifications. By using the information provided, the user assumes all risks in connection with such use.

PLEASE REFER TO THE WARRANTY PAGE FOR SPECIFIC WARRANTY INFORMATION.

AUTHORIZED SERVICE AGENT LISTING

Reference the listing provided with the unit or for an updated listing go to the website or call customer service to find an agent.

Business hours: 8:00 a.m. to 4:30 p.m. Central Standard Time

Telephone: 314-678-6303

Fax: 314-781-2714

Email: customerservice@star-mfg.com

Website: www.star-mfg.com

Please visit www.starwebconnect.com/manuals.aspx for digital versions of any documents associated with this unit.



GENERAL SAFETY INFORMATION

This equipment is designed and sold for commercial use only, and is intended for use by personnel trained and experienced in its operation. This is not sold for consumer use in and around the home nor for use directly by the general public in food service locations.

Before using your new equipment, read and understand all the instructions and labels associated with the unit prior to putting it into operation. Make sure all people associated with its use understand the units operation and safety before they use the unit.

GENERAL INSTALLATION INFORMATION

The unit is shipped fully assembled and ready to plug into a standard outlet specified for its voltage and amp draw. If improper electrical supply can be determined through troubleshooting, contact a qualified electrician prior to using the unit. Removal or replacement of the power cord or plug will void the warranty. Should you require assistance, contact your local authorized service agent for any service or required maintenance.

Allow enough space around the toaster for adequate ventilation. Make certain this unit is not located near other appliances which may produce grease vapor, such as fryers, griddles, etc. In the event this is unavoidable, ducting will be necessary to supply this unit with an adequate amount of clean, cool air. It is recommended that you leave at least a one [1] inch (25 mm) gap on each side. Do not operate the unit without the PTFE sheet and belts properly positioned. If operated improperly, bun sticking and poor toasting may occur. Before using the unit for the first time, ensure to clean the toaster properly. Refer to the cleaning section of this manual for cleaning instructions.

ELECTRICAL CONNECTION

Before making any electrical connection to this unit, check that the power supply is adequate for the voltage, amperage, and requirements stated on the rating plate. Make certain to disconnect the unit from the power source before installing or removing any parts. Be absolutely sure that the ground connection for the receptacle is properly wired. Do not connect equipment to power without proper ground connections. Improper grounding may result in personal injury or fatality.



DO NOT CUT THE POWER CORD OR REMOVE THE PLUG OR REMOVE THE GROUNDING PRONG FROM THE PLUG.



CONNECT/PLUG UNIT INTO DEDICATED AC LINE ONLY SPECIFIED ON THE DATA PLATE OF THE UNIT.



DO NOT IMMERSE OR LET THE UNIT STAND IN WATER.



DO NOT HOSE DOWN THE UNIT OR THE TABLE/COUNTER IF THE UNIT IS ON THE TABLE/COUNTER.



KEEP AWAY FROM RUNNING WATER.

ELECTRICAL REQUIREMENTS

208-240 volts and a NEMA 6-15P is required.



CONVEYOR ACCESS AND REMOVAL

THESE PARTS GET VERY HOT WHILE IN USE, SO PLEASE MAKE CERTAIN THAT THE UNIT HAS COOLED BEFORE ATTEMPTING THE BELOW PROCEDURES. IF THERE IS AN IMMEDIATE NEED TO PERFORM THIS PROCEDURE WHILE THE UNIT IS STILL HOT, MAKE CERTAIN TO WEAR APPROPRIATE THERMAL PROTECTION. ALWAYS USE INSULATED MITTS OR GLOVES IF THE MACHINE IS STILL WARM TO PREVENT BURNS.

- i. The outer conveyor cover on the front and rear fold down by lifting up on the cover so that the open hole in the slot allows the cover to be pulled over the retaining tab as pictured and pulling outward from the top so that the cover swings out and down on its pivot point. Be careful when lowering cover as it will rest on the finished side of the metal.
- ii. Once the cover has been folded down, one side of the conveyor belt on each side will be visible for cleaning and inspection.
- iii. In order to rotate the conveyor[s] out and down, pull the conveyor[s] gently outward [one at a time] grasping the area where the adjustment knob is located while supporting the conveyor weight with your other hand. The other side of the conveyor belt will also now be visible for cleaning and inspection.
- iv. If the belt needs to be replaced or removed for any reason, the conveyors, when folded out in a horizontal position, can also be removed. First, remove the left side panel (opposite the control side). Then slide the conveyor away from the motor coupler and lifting up on the conveyor, side opposite the toaster controls/thermostat so the pin on that side slides upward through a slot in the chassis and in doing so allows the drive shaft to be removed from the motor. Be careful with the conveyor assembly as it can easily be damaged from being dropped or mishandled. When removing both conveyors, make note as to which conveyor is which as they will only function correctly if they go back into their original position.

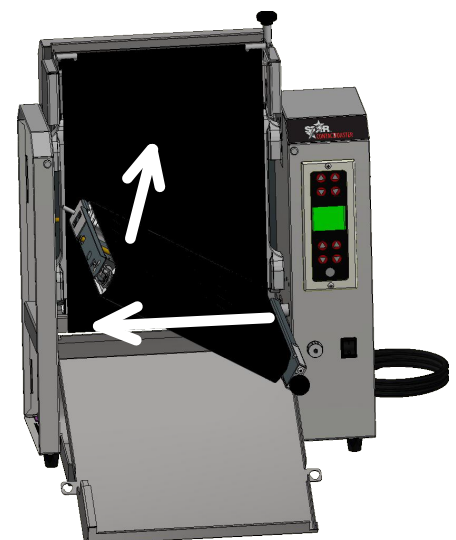
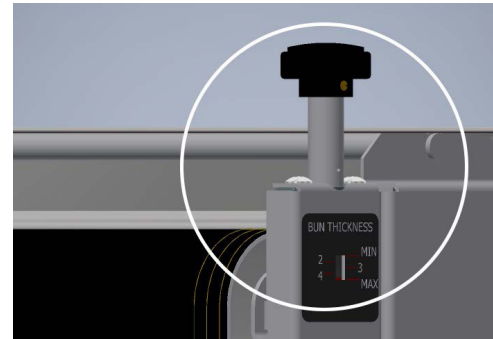

- i. If the belt needs to be removed from a conveyor, the conveyor must first be removed from the unit.

The upper roller [the side with the knob] must be compressed so that the locking pin can be placed in position to hold the roller in its compressed position. Be careful if attempting to do this with the conveyor set vertically as the bottom roller will allow the assembly to move unpredictably, potentially causing damage or personal injury. Reinstall the belt, making certain the belt is facing the correct direction for the best performance. Once in place, release the conveyor to return tension to the belt. The guides on the belt must be correctly aligned with the rollers.

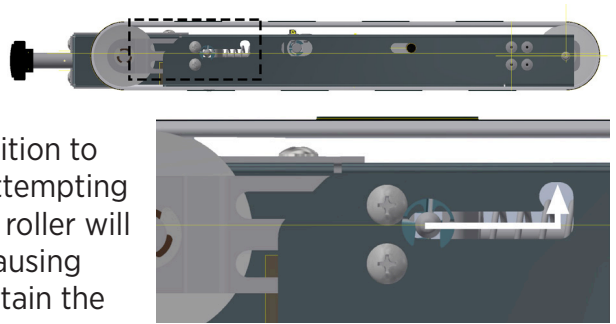

platen side [facing inside]

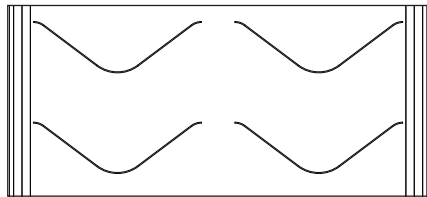

conveyor cover side [facing outside]

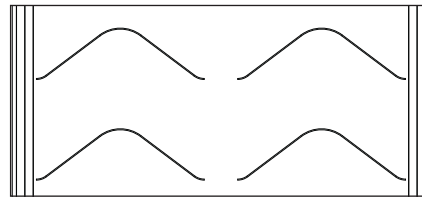

- ii. Once you have finished cleaning/inspecting the unit, place the conveyors back in their original positions, if they have been removed, by setting the control side drive shaft in position and sliding the pin on the opposite side into the slot in the chassis to mount in. Next, push the conveyor assemblies into their vertical positions, ensuring they lock into place. The side panel must be installed by aligning the bottom slot first, then align the thumb screw at the top. Secure the side panel with the thumb screw until it is hand tight.



- iii. Finally, rotate the covers back up and lock them in place by sliding them over the retaining tab and lowering the cover into the locked position. At this time the toaster would be ready for use if everything has been reinstalled correctly.



BUN THICKNESS ADJUSTMENT



Bun thickness adjustment is controlled with a simple twist knob that can adjust and be set anywhere between 0.125 in. (3 mm) and 1 in. (25 mm). The thickness setting is adjusted independently on the front and rear. An indicator on the side of the conveyor will display relative thickness.

PTFE [NON-STICK] SHEET REPLACEMENT

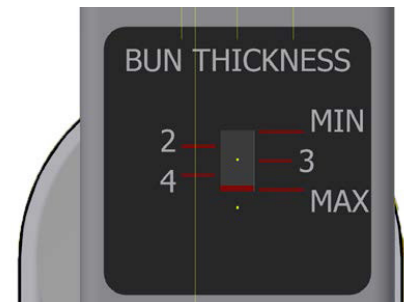
Wait until the unit has cooled sufficiently. Begin by lowering both conveyors for easy access. Lift the sheet off from the top of the unit. Place the new sheet in the correct position. Place the conveyors and covers back in position.



DAILY OPERATION

-  CERTAIN SURFACES ARE EXTREMELY HOT DURING OPERATION AND CARE SHOULD BE TAKEN WHILE USING THIS UNIT.
-  DO NOT LEAVE THE UNIT IN OPERATION WITHOUT AN ATTENDANT.
-  DO NOT LEAVE THE UNIT AT HIGH TEMPERATURE WHEN NOT IN USE OR DURING IDLE PERIODS.

ELECTRONIC VERSION [SCT4000E AND SCT4000E-RR]

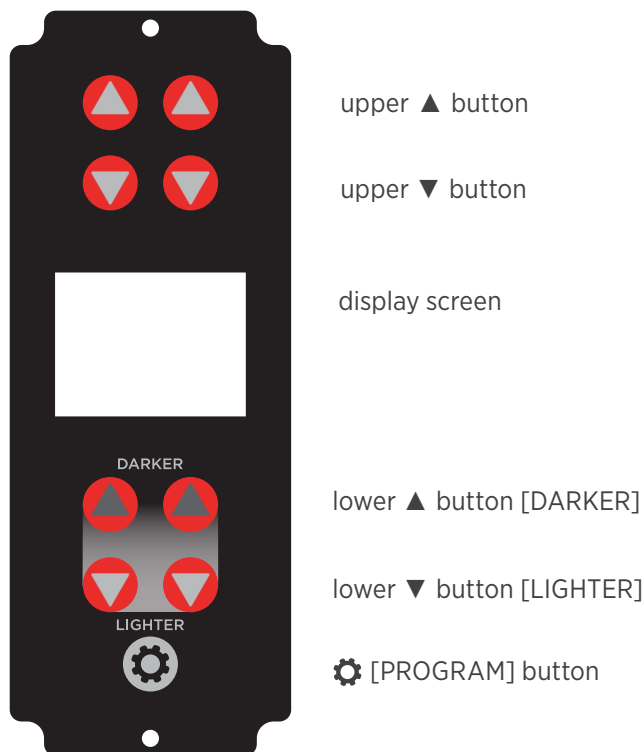

START UP / PREHEAT

- i. When the toaster has been plugged into a suitable outlet and power supply, the power switch can be flipped to turn the unit on.
- ii. The toaster will enter into its *PREHEAT* mode and a percentage will appear on the screen. The fan and belts will turn on and the platen will begin to heat up.
- iii. The unit will, by default, use the belt speed and set point settings last used before the previous shutdown.

MAIN MENU

- i. **DISPLAY**—Once the toaster has been pre-heated, menu products will appear in two lists on the display separated into a front and back side. The front conveyor and heaters are controlled by the left side buttons and the back side is controlled by the right side buttons.
- ii. **UPPER ▲/▼ ARROWS**—The selected preset can be changed simply by pressing the upper ▲ or ▼ on the corresponding side until the desired preset is highlighted. The speed setting change will occur instantly.
- iii. **DARKER/LIGHTER**—The “DARKER” and “LIGHTER” ▲ and ▼ buttons can be pressed up to 6 times in each direction to activate a conveyor speed adjustment mode from the main menu. The “DARKER” and “LIGHTER” ▲ and ▼ buttons will cause the belt to slow down or speed up on the corresponding side allowing quick adjustments in toasting color. Selecting “LIGHTER” will increase speed, while selecting “DARKER” will decrease speed. Adjustments made here will reset to the original time after the cycle time has finished.





 DO NOT IMMERSE THE UNIT IN WATER OR LET THE UNIT STAND IN WATER.

 DO NOT USE A NON-STICK SPRAY ON THE CONVEYOR BELT, IT WILL CAUSE A STICKY BUILD-UP AND INCREASE STICKING.

 DO NOT HOSE DOWN THE UNIT OR THE TABLE/COUNTER IF THE UNIT IS ON THE TABLE/COUNTER.



 KEEP HARD AND/OR SHARP OBJECTS AWAY FROM SILICONE BELTS AND PTFE SHEETS.

 DO NOT CREASE OR FOLD SILICONE BELTS OR PTFE SHEETS.

 DO NOT SUBMERGE SILICONE BELTS OR PTFE SHEET AND MAKE CERTAIN TO CLEAN ON A FLAT, SMOOTH SURFACE.

OTHER TOASTER FUNCTIONS [SCT4000E AND SCT4000-RR]

COOLDOWN MODE

COOLDOWN mode can be activated by holding the  button and the both upper  buttons for a few seconds. *COOLDOWN* mode causes the heaters to be turned off, but the conveyors, display, and fan to continue functioning. This mode can be used for cleaning or simply cooling off the unit.



CLEANING

SUGGESTED CLEANING SUPPLIES

- i. mild detergent and water
- ii. surface sanitizer
- iii. white non-scratch polishing pad
- iv. clean cloth rag

CLEANING PROCEDURE

Preventive maintenance for your toaster consists of the following recommended cleaning procedures. To keep your toaster in its best operating condition, these steps should be performed on a daily or weekly basis as required.

- i. Turn the toaster off. On the electronic version, you can also activate *COOLDOWN* mode by pressing and holding the  button and the upper left and upper right  buttons. This causes the toaster to turn off the heating elements but keep power to all other parts and the display.
- ii. Once cool, open the conveyor cover on each side. Apply a mixture of detergent and water to the white polishing pad. Gently scrub each side of the conveyor belt to clean residual debris/buildup from them. Next, remove the PTFE sheet and lay it out on a flat smooth surface. Then, scrub the sheet gently to remove debris/buildup. Make certain to remove any buildup on the platen itself where it meets the body as well.
- iii. Rinse the pad and repeat as necessary until clean of noticeable debris.
- iv. Rinse the non-scratch pad to remove all detergent and then soak with clean, warm water. Ring the pad out so that it is slightly damp, and wipe down the areas until it is clean of any detergent.
- v. Wipe the belts and PTFE with a clean cloth dampened with sanitizer solution. Allow to air dry and reinstall the PTFE sheet.
- vi. Rinse the non-scratch pad and then soak with clean warm water. Ring the pad out so that it is only damp, and wipe exterior areas of the toaster, making sure to keep moisture away from the control on electronic models as well as keeping moisture out of vents and louvers in the chassis.
- vii. Once dry, the unit is ready for use.

PRODUCT SETTINGS AND ADJUSTMENTS [SCT4000E AND SCT4000E-RR]

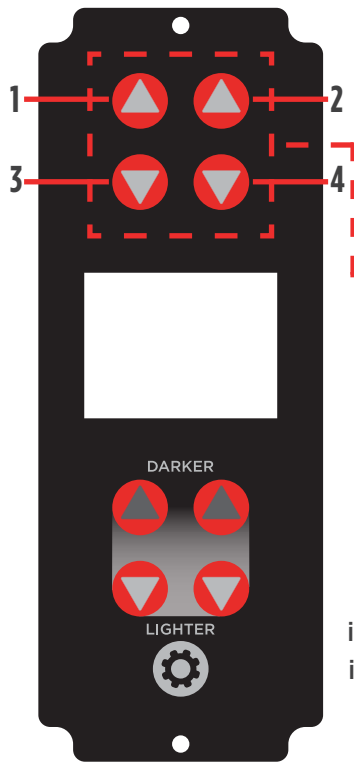



 **DON'T REMOVE USB FLASH DRIVE OR TURN OFF POWER UNTIL THE PROGRAMMING IS COMPLETE. CAUTION TOASTER MAY NOT FUNCTION PROPERLY.**

The Star contact toaster comes with pre-programmed factory default settings for toasting some products, although the settings may need to be adjusted to accurately toast your specific buns on non-specialty models. Up to sixteen [16] user-defined settings can be saved at one time. Authorized users can customize product names, temperature, and belt speed.

THIS MENU WILL USE A SECURITY CODE THAT IS A COMBINATION OF THE TOP 4 BUTTONS. A DEFAULT CODE HAS BEEN SET BY THE FACTORY— BOTTOM RIGHT [4], TOP LEFT [1], BOTTOM LEFT [3], THEN TOP RIGHT [2]. EACH ARROW BUTTON REPRESENTS A NUMBER 1-4 EVEN IF A NEW CODE IS ENTERED, THIS CODE WILL ALWAYS WORK AS A MASTER CODE. A NEW CODE CAN BE ENTERED BY PRESSING THE LEFT “DARKER” ▲ BUTTON AND ENTERING THE DESIRED CODE TWICE.

CHANGING CONVEYOR SPEED [TOAST TIME]

- To adjust the conveyor speed [toast time], begin by pressing the  button.
- Using the upper, left ▲ and ▼ buttons, select the product to be adjusted.
- Using the upper, right ▲ and ▼ buttons, change the speed [toast time].
- Hit  again to save changes.

CHANGING PLATEN TEMPERATURE

- To adjust the platen temperature, begin by simultaneously pressing the  button and the lower, right ▲ button.
- Using the upper, right ▲ and ▼ buttons, change the platen temperature.
- Hit  again to save changes.



PROGRAMMING

LOADING A PRODUCT FILE

- Ensure the toaster is powered on before beginning.
- Plug a USB flash drive containing the desired .csv file into the receptacle.
- The display will automatically search for all files with the correct .csv extension. These will then be shown on the display.
- Select the desired file to upload with the upper right side ▲ and ▼ buttons and the  button.
- Programming may take up to several minutes. The display will reset when finished, and the toaster will resume normal operation.

EDIT PRODUCT SETTINGS [ON TOASTER]

THE SETUP MENU IS USED TO EDIT THE PRODUCT NAME, CONVEYOR SPEED, OR HEATER SETTING FOR ANY EXISTING PRODUCTS.

- To access the setup menu, while on the main screen, press and hold the  button for a few seconds until the setup screen appears.
- The selected product can be changed using the ▲ and ▼ buttons on the upper left side.
- The right “DARKER” and “LIGHTER” ▲ and ▼ buttons are used to cycle between the other settings.
- The belt speed values can be changed using the upper right side ▲ and ▼ buttons. All values are set in whole numbers.
- Once finished, press the  button to exit to the main menu. Settings update instantly.

EDITING PRODUCT NAME

- i. Once in the setup menu, press the left “LIGHTER” ▼ button on the product name to begin editing.
- ii. Use the upper right ▲ and ▼ buttons to cycle through characters and the upper left ▲ and ▼ buttons to move selection from character to character. Spaces cannot be used. Any characters after a space will not appear in the product name in the menu. The name can be up to a maximum of nine [9] characters.
- iii. Press the ⚙ button to save and exit.

ADVANCED PROGRAMMING [SCT4000E AND SCT4000E-RR ONLY]

CREATING A NEW UPDATE FILE

- i. If a .csv file with the correct format for uploading new preset names and settings into the toaster has not already been loaded onto a USB flash drive, a file with the correct format can be generated by plugging a USB flash drive into the toaster while it is on. *A flash drive formatted in FAT32 is strongly suggested.*
- ii. A screen will appear prompting an upload or download option for the toaster. By pressing the upper, left-side ▼ button, a .csv file will be generated with the toaster’s current product settings and names called “CONTACTD”.
- iii. Remove the flash drive and insert it into a computer with Microsoft Excel or another application capable of creating .csv files. Open the file and change the product names and settings to the desired values. Save the file as a .csv file.

FILE REQUIREMENTS

- *PRODUCT NAMES* will only appear in upper case when uploaded and must be 9 characters or less.
- *CYCLE TIME* must be a whole number between 4 and 50.
- *FILE NAME* will only appear in upper case when uploaded, must be 8 characters or less.

CELSIUS/FAHRENHEIT ADJUSTMENT [SCT4000E AND SCT4000E-RR ONLY]

To change between Celsius and Fahrenheit, hold the upper left ▲ button and the ⚙ button until the screen changes, then use the upper left ▲ and ▼ buttons to toggle between Celsius and Fahrenheit. *Make certain not to change the offset setting at any point while in this menu.*

EXPLODED VIEW

ELECTRONIC [E] VERSION AND COMMON COMPONENTS

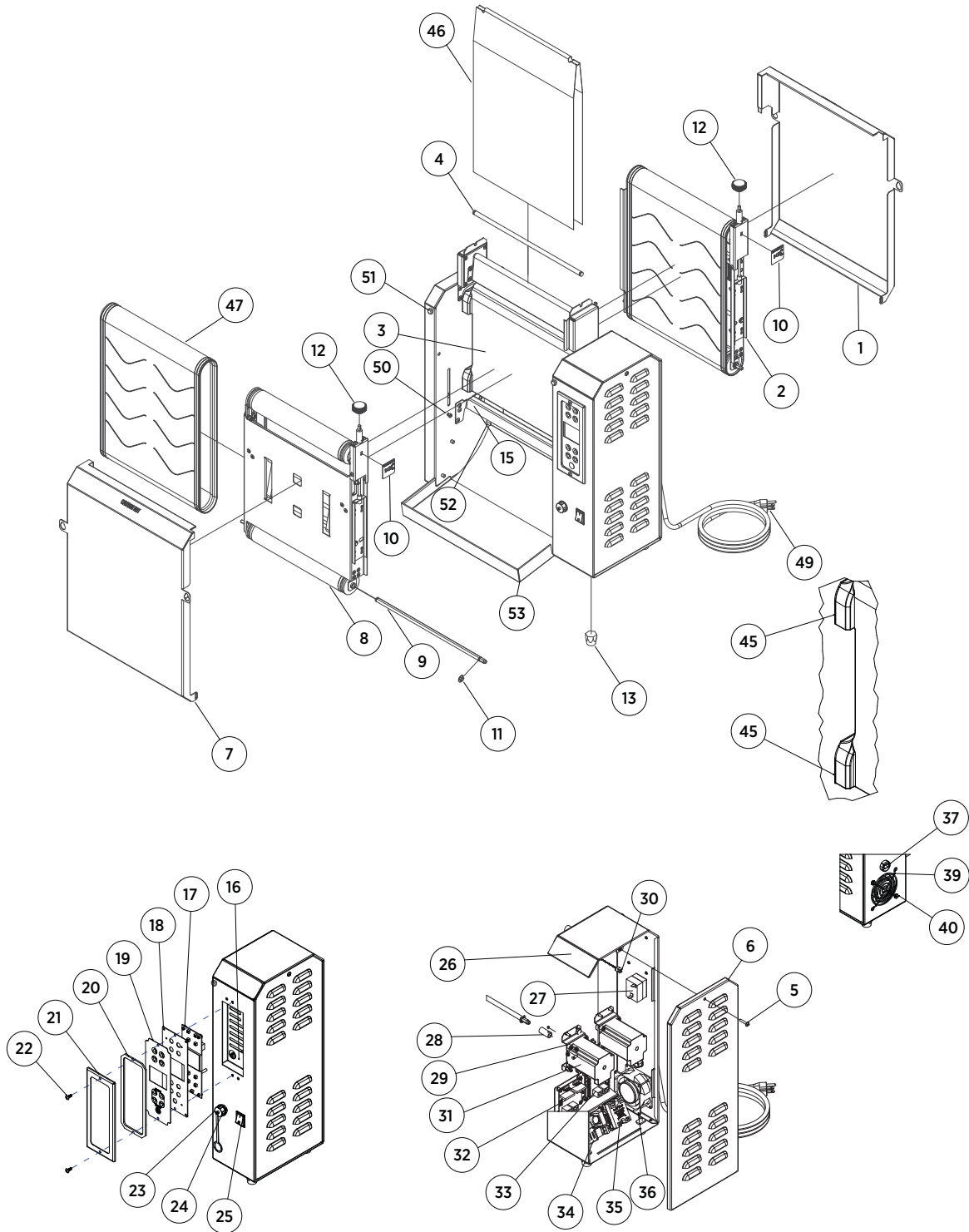

SCT4000E and SCT4000E-RR CONTROL LABEL REPLACEMENT

- i. Remove the two [2] screws holding the bezel on.
- ii. Lift off the bezel, gasket, and label.
- iii. Place new label, bezel, and gasket in place in the order displayed on the right.
- iv. Tighten down the two [2] screws that hold the bezel in place.

PARTS LIST

Critical parts listed with grey “REF NO” boxes.

REF NO	PART NUMBER	MODEL	DESCRIPTION	QTY	PAGE NO
1	HC-Z22512	ALL	conveyor cover, rear	1	8
2	HC-120437	ALL	rear conveyor assembly [INCLUDES PARTS 9–12, DOES NOT INCLUDE BELT]	1	8
3	2F-Z21590	ALL	platen	1	8
4	2V-Z21506	ALL	PTFE sheet bar	1	8
5	2C-35733	ALL	8-32 screw	2	8
6	HC-Z21437	ALL	side cover	2	8
7	HC-Z22511	ALL	conveyor cover, front	1	8
8	HC-120436	ALL	front conveyor assembly [INCLUDES PARTS 9–12, DOES NOT INCLUDE BELT]	1	8
9 ¹	2V-Z21574	ALL	conveyor drive rod	2	8
10 ¹	2M-Z22500	ALL	bun thickness label	2	8
11 ¹	2A-Z12583	ALL	0.375-inch e-clip	8	8
12 ¹	2R-Z22533	ALL	twist knob	2	8
13	2A-Z11501	ALL	foot	4	8
14	HC-Z22374	ALL	bun tray	1	8
15	HC-Z21515	ALL	lower crossbar	1	8
16	HC-Z21513	ALL	guard	1	8
17	2E-Z21591	SCT4000E	display board	1	8
	2E-Z22376	SCT4000E-RR			
18	HC-Z20995	ALL	control panel cover	1	8
19	2M-Z21066	ALL	control label overlay	1	8
20	2I-Z21052	ALL	control bezel gasket	1	8
21	HC-Z20994	ALL	control panel bezel	1	8
22	2C-41620	ALL	8-32 screw	22	8
23	2E-Z21011	ALL	USB cap	1	8
24	2E-Z21002	ALL	USB connector	1	8
25	2E-Z21127	ALL	rocker switch	1	8
26	2M-Z22069	ALL	name label	1	8
27	2E-Z21585	ALL	high limit thermostat	1	8
28	PS-120443	ALL	motor coupler w/set screw	2	8
29	HC-Z21524	ALL	motor mount	2	8
30	2E-Z22074	ALL	rtd probe	1	8
31	2E-Z21523	ALL	stepper motor	1	8
32	2E-Z22653	ALL	motor board	1	8
33	2E-Z21586	ALL	cpu board	1	8
34	2E-Z22619	ALL	AC/DC converter	1	8
35	2E-Z22494	ALL	high limit relay	1	8
36	2E-Z21003	ALL	cooling fan	1	8

¹These parts are also included in assemblies [HC-120436](#) and [HC-120437](#).

PARTS LIST

Critical parts listed with grey "REF NO" boxes.

REF NO	PART NUMBER	MODEL	DESCRIPTION	QTY	PAGE NO
37	2K-Y6764	ALL	strain relief bushing	1	8
38	HC-Z21524	ALL	motor mount	2	8
39	2R-Z18593	ALL	fan guard	1	8
40	2C-Z5883	ALL	10-24 self-tapping screw	2	8
44	2C-Z7165	ALL	8-32 keps nut	8	8
45	2H-Z21527	ALL	PTFE platen insulation	4	8
46	2I-Z21439	ALL	PTFE sheet	1	8
47	2I-Z21454	ALL	silicone belt	2	8
49	D6-FG0005	ALL	6-15p cordset	1	8
50	2C-Z21462	ALL	shoulder screw, 8-32	4	8
51	2V-Z22539	ALL	standoff, Blind	4	8
52	2C-Z21526	ALL	cap screw, 8-32	4	8
53	HC-Z22374	ALL	bun tray sct4000	1	8
OPTIONAL ACCESSORIES					
	9Y-SCTBWP	ALL	perforated butter wheel		
	9Y-SCTBWS	ALL	smooth butter wheel		
	9Y-SCTSHEET-B	ALL	pack of 10 replacement PTFE sheets for use with butter		

WIRING DIAGRAM

SCT4000E and SCT4000E-RR

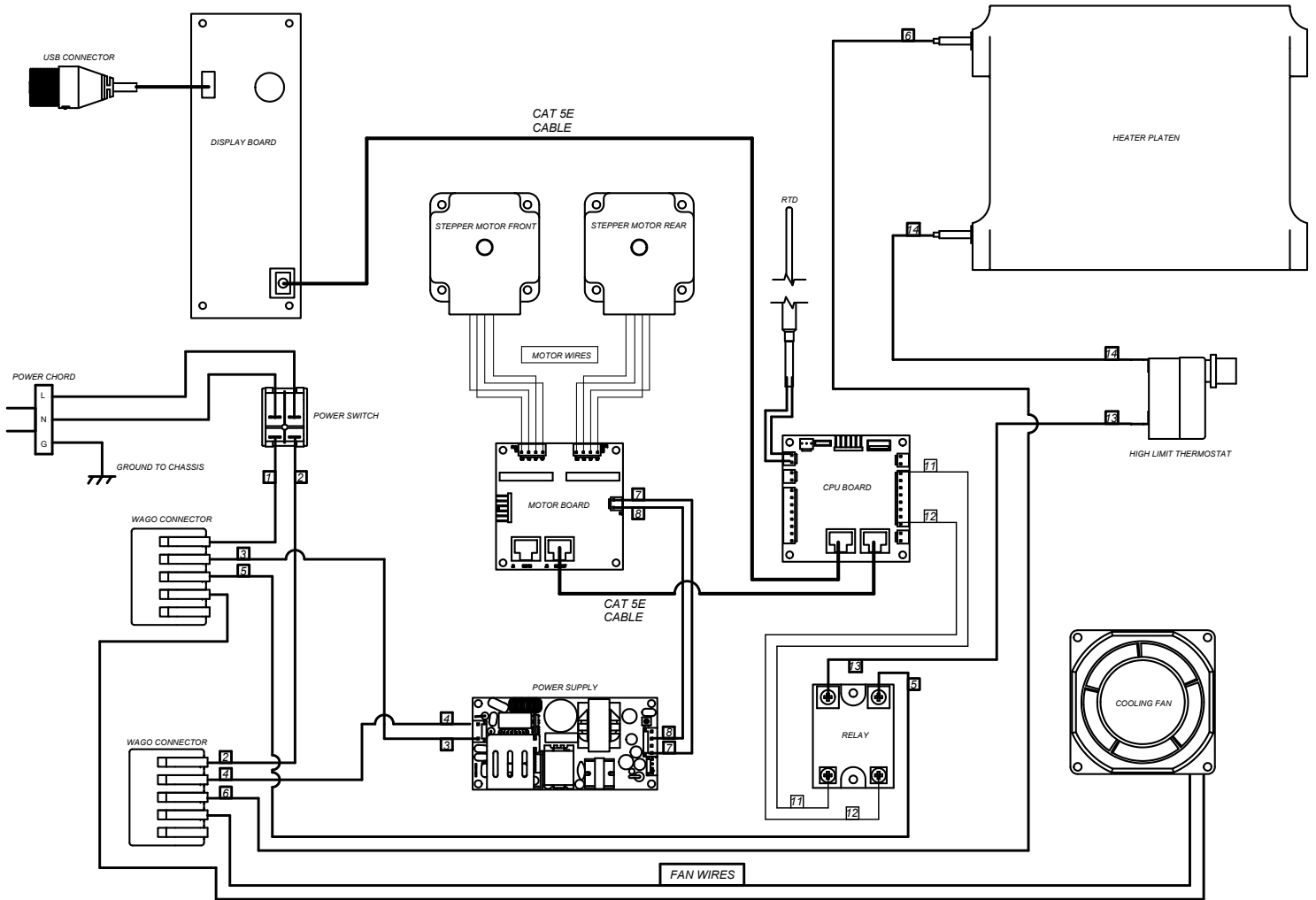

2M-Z21458

SPECIFICATIONS

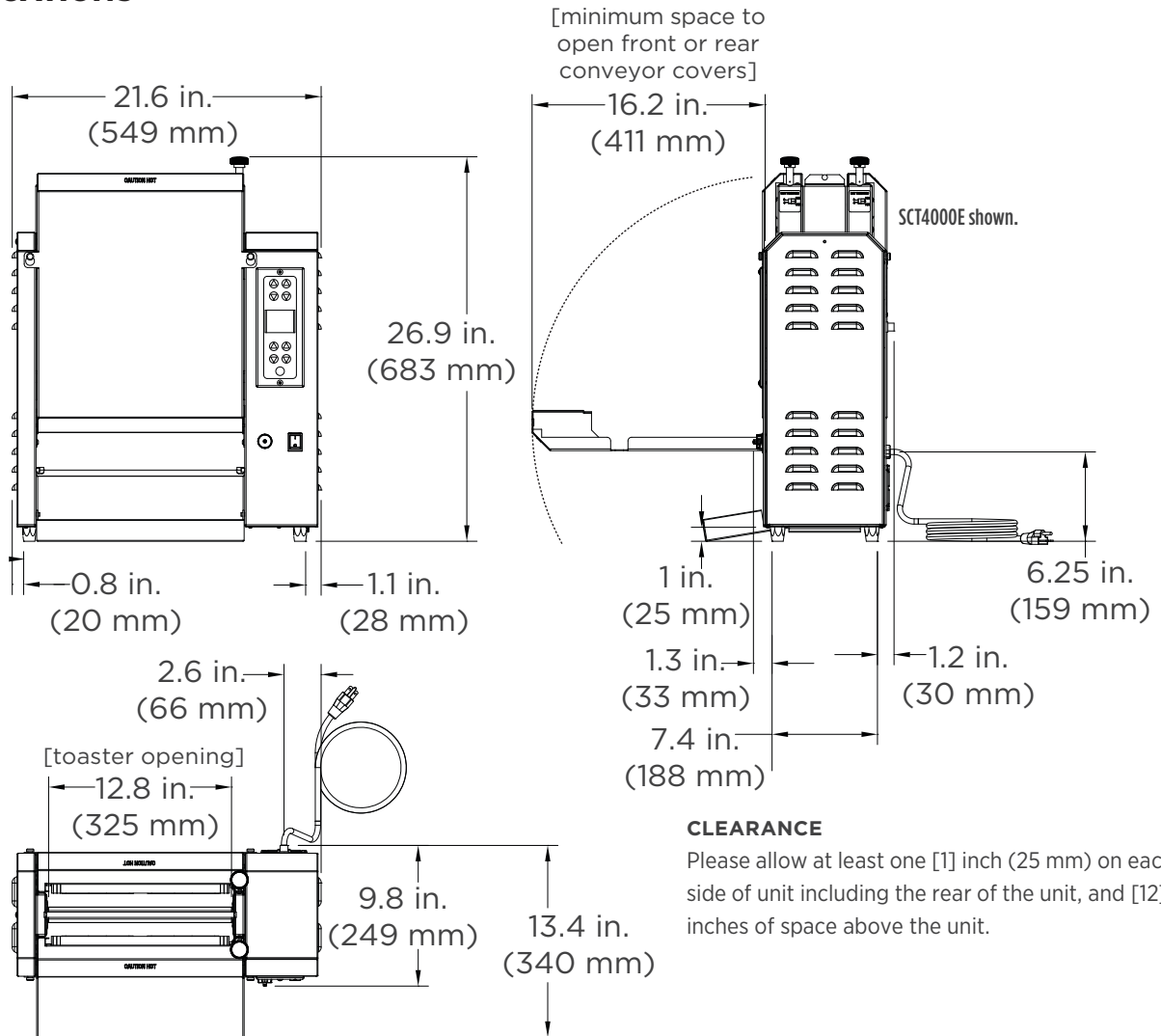

MODEL	HEIGHT	WIDTH	DEPTH ²	VOLTS	AMPS	WATTS	APPROX. SHIP WEIGHT	APPROX. WEIGHT INSTALLED
SCT4000E and SCT4000E-RR	26.9 in. (683 mm)	21.6 in. (549 mm)	9.8 in. (249 mm)	208 230 240	9.6 10.6 11.1	2,000 2,446 2,663	100 lb. (45.4 kg)	75 lb. (34 kg)

²without bun tray [extends out and adds 3.6 in. (91 mm) to unit's base depth] or optional butter wheel [butter wheel extends out and adds 4.2 in. (107 mm) to unit's base depth].

Units sold for use in the U.S.A. and Canada will come with a factory-attached cord using a 6-15P plug.



TROUBLESHOOTING



THIS UNIT IS NOT USER SERVICEABLE. NO PERSONNEL OTHER THAN AN AUTHORIZED TECHNICIAN SHOULD ATTEMPT TO MAKE REPAIRS OR SERVICE THIS UNIT AT ANY POINT.



REMOVAL OF ANY BODY PANEL OR FUSE PRESENTS THE POSSIBILITY OF ELECTROCUTION AND SHOULD NOT BE PERFORMED WHILE THE UNIT IS CONNECTED TO ITS POWER SOURCE. THE UNIT SHOULD BE UNPLUGGED OR DISCONNECTED BEFORE ANY SERVICE IS ATTEMPTED.

SYMPTOM	POSSIBLE CAUSES / SOLUTIONS	
conveyor not turning	the motor is not turning the conveyor	When the toaster is first powered on, the front conveyor will not start immediately. If this is the cause, the conveyor will start before the end of the <i>PREHEAT</i> mode.
		Make certain the conveyor is properly in place and that when in place the drive shaft is engaged. If the conveyor is properly in place and does not properly engage the motor, the drive shaft may need to be replaced.
		If the motor is working and the conveyor is properly engaged, the motor coupling may be spinning on the motor output shaft. Check the set screw that seats the motor coupling to make sure it is securely in place.
		If the motor is not working, begin by checking the wiring to make sure it is properly connected and not damaged. If this is the case and the motor is receiving power, the motor may need to be replaced.
		If the motor is not receiving power, check the motor board. If the motor board is receiving power and has no output to the motor, the motor board may need to be replaced.
	If the motor board is not receiving power, check the connection to the other boards and check the other boards for proper function.	
	conveyor belt slipping	Check to make certain the conveyor is not locked in the compressed position used to change the belt. Also check to make certain the belt is properly aligned over the rollers.
under-toasted product	unit is not heating/toasting properly	Check to make sure the power to the unit is on.
		Check the product settings and bun adjustment.
		Check the heating element to confirm it is not damaged.
		Check the high limit to make sure it has not been tripped.
		Check the RTD probe and CPU board.
over-toasted product	unit is not heating/toasting properly	Check the product settings and bun adjustment.
		Check the relay for proper function.
		Check the RTD probe and CPU board.
ERROR CODES [SCT4000E AND SCT4000E-RR ONLY]		
CODE	EXPLANATION	POSSIBLE CAUSES / SOLUTIONS
RTD OPEN!	RTD probe circuit is open	RTD probe circuit is open due to damage to wiring, connection, or probe
		RTD probe circuit is not connected
RTD SHORT!	RTD probe circuit is shorted	RTD probe circuit is shorted internally or has a shorted wire
HIGH TEMP!	detected temperature is 75° F (42° C) or more over set point temperature	failed or malfunctioning high limit thermostat, relay, or control board
LOW TEMP!	after <i>PREHEAT</i> process, the detected temperature is 50° F (28° C) or more under set point temperature for more than 15 minutes	failed or malfunctioning high limit thermostat, heating element, relay, or control board

STAR MANUFACTURING INTERNATIONAL INC.

256 Hobson Street • Smithville, Tennessee 37166

Telephone 800 264 7827 • Fax 314 781 5445

www.star-mfg.com

Printed in the U.S.A. • 2M-Z21667 • Rev 1 • 09.2019

Specifications are subject to change without notice.

